



Campbell STRUCTURAL

Robert L. Campbell Structural Engineer, P.C.

200 E. 16th Street, Suite 100
Yuma, Arizona 85364
Phone: (928) 726-2646
Fax: (928) 726-2629

Robert L. Campbell, P.E., S.E.
Consulting Structural Engineer

e-mail: rob@campbellstructural.com

**BET-KO HANGAR
3681 BURCH WAY, YUMA, AZ
STRUCTURAL EVALUATION**

FOR

**YUMA COUNTY AIRPORT AUTHORITY
2191 E. 32ND ST, STE 218
YUMA, AZ 85365**

Prepared by:

Robert L. Campbell Structural Engineer, P.C.
200 E. 16th Street, Suite 100
Yuma, AZ 85364



Expires 6/30/2011

TABLE OF CONTENTS

<u>TITLE</u>	<u>PAGE</u>
SCOPE/STATEMENT OF PURPOSE.....	3
LIMITATIONS.....	3
ASSUMPTIONS.....	3
DESCRIPTION OF BUILDING.....	4
FIELD OBSERVATIONS.....	4
ANALYSIS CRITERIA.....	4
RESULTS OF ANALYSIS AND CODE REVIEW.....	5
RECOMMENDATIONS AND CONCLUSIONS.....	6
APPENDIX A: FRAMING KEYPLAN	
APPENDIX B: MATERIAL PROPERTIES AS TESTED BY WESTERN TECHNOLOGIES INC.	
APPENDIX C: STRUCTURAL CALCULATIONS	

SCOPE/STATEMENT OF PURPOSE

The intent of this report is to evaluate the existing prefabricated metal building hangar for the proposed Yuma Pilot Center renovation project. This evaluation was initiated by Craig Williams with *Yuma County Airport Authority*.

Investigatory site visits were performed by Robert L. Campbell, P.E., S.E., Kevin Burge, P.E. and Emmanuel Jimenez on November 13, 2009 and on November 16, 2009 by Robert L. Campbell, P.E., S.E. and Kevin Burge, P.E.

The scope of services for this report is limited to the following:

1. Observe the existing building.
2. Obtain field measurements on the existing rigid frame and purlins.
3. Perform structural calculations on the capacity of the existing rigid frame and purlins.
4. Prepare a written report based on our structural calculations and the 2003 *International Existing Building Code* (IEBC).

LIMITATIONS

This report is limited to a structural review only. Issues such as building function, aesthetics, etc. have not been addressed, nor have architectural, electrical, mechanical or plumbing items been reviewed.

It should be noted that certain assumptions have been made regarding existing conditions. Because some of these assumptions may not be verifiable without expending additional sums of money, or destroying otherwise adequate or serviceable portions of the building, it should be clearly understood that the conclusions and recommendations made in this report are based solely on the available information. It is possible that additional deficiencies may exist which were not discovered during our review.

ASSUMPTIONS

The conclusions and recommendations discussed in this report are based on the following assumptions:

1. The existing foundation system is assumed to be adequately designed for the building reactions. Foundation drawings are not available and only destructive demolition will provide the information required to perform a foundation analysis. We did not observe any significant foundation cracks that would indicate differential settlement.
2. Test specimens were cut from the web of the rigid frame and from the web of a wall girt. These specimens were tested by *Western Technologies Inc.* for yield strength, tensile strength and elongation. These test results were used in the structural evaluation of the building and are assumed to be representative of the steel used throughout the building.
3. The building alteration, as proposed, is assumed to not increase the relative seismic hazard per IEBC Table 812.1.1. This assumption is based on a new occupancy classification of B.
4. It our understanding, based on information from the City of Yuma, construction of this building at its current location was completed in late 1987.

DESCRIPTION OF BUILDING

The existing hangar portion of the building is a single story, prefabricated metal building consisting of a 60 ft. by 80 ft. building with a 20 ft. by 80 ft. lean-to. The overall dimensions are 80 ft. by 80 ft. Appendix A shows a key plan of the building layout.

The roof construction consists of metal roof sheeting on light gage metal Z purlins supported by rigid frames. The rigid frames are spaced 20 ft. o.c. and span north-south. The lean-to portion of the building occurs along the north side wall of the rigid frames. The north side wall of the lean-to occurs along the south wall of the existing office portion of the complex.

The south, east and west exterior walls typically consist of metal wall sheeting on light gage metal Z wall girts supported by the rigid frames. The east and west exterior walls also have large rolling sectional hangar doors. There is no wall framing along the north wall, which abuts the existing office building.

It is assumed the foundation system consists of cast in place concrete spread footings. All areas of the building have a concrete slab on grade.

The main wind and seismic force resisting system consists of structural steel moment frames in the north-south direction. East-west direction lateral forces are resisted by roof cross bracing rods, wall cross bracing rods along the south side wall and a K brace style portal frame along the north side wall.

FIELD OBSERVATIONS

The following items were observed while we were on site:

1. Review of the overall building layout (bay spacing, column layout, quantity of frames).
2. Rigid frame flange and web plate thickness and width were field measured.
3. Light gage steel roof purlins were field measured.
4. Light gage steel wall girts were field measured.
5. It is apparent, based on our field observations; this hangar building had previously been erected at a different location.

ANALYSIS CRITERIA

A structural analysis on the metal building was modeled utilizing the field measurements and testing results. The analysis evaluated the structural capacity of the existing building to determine if any collateral load allowance exists for supporting additional loads such as fire sprinkler piping, insulation and ceiling. The structural analysis was performed in accordance with the 2003 *International Building Code (IBC)* and the *American Institute of Steel Construction (AISC) ASD 9th Ed. Of the "Steel Construction Manual"* for vertical loading and the 1985 *Uniform Building Code (UBC)* for wind and seismic loading using the following design criteria:

- | | |
|----------------------------------|---|
| 1. Roof dead load | 2.1 psf plus frame weight |
| 2. Roof collateral load | Analysis is to determine allowable collateral load. |
| 3. Roof live load | 20 psf less tributary area reductions (12 psf on rigid frame) |
| 4. Material Strength/Properties: | |
| a. Structural steel | Fy = 50 ksi (Per Testing) |
| b. Light gage purlins and girts | Fy = 60 ksi (Per Testing) |
| c. Bolts at haunch | ASTM A325 HSB (Observed) |

RESULTS OF ANALYSIS AND CODE REVIEW

The proposed renovations to the existing hangar building are classified as Level 3 Alterations in the IEBC. The IEBC breaks down the structural requirements in four categories:

1. If no additional load is added to the building, no evaluation is required.
 - a. This option requires no new loading. No new materials or equipment may be supported from the building.
2. If any new vertical loads are added to the structure, the components supporting these new loads shall meet the requirements in the *2003 International Building Code (IBC)*.
 - a. The existing purlins have no additional capacity to support loads beyond what they are currently supporting.
 - i. Any new material or equipment supported from the roof purlins will require new structural purlins.
 - b. The existing rigid frame rafters have enough capacity to support an additional 1.5 psf. Any loads beyond this amount will require the structural alterations on the rigid frame rafters.
 - c. Three of the existing rigid frame columns require structural alterations regardless of the amount of additional vertical load. These columns are located at grids 2-C, 3-C and 4-B. Refer to appendix A for a location key plan.
3. If the seismic base shear is increased by more than 5 percent because of the alterations, the evaluation and analysis shall demonstrate that the altered building complies with the wind and seismic loads applicable at the time the building was constructed.
 - a. The following minimum structural alterations are required:
 - i. New or altered purlins are required to support the sprinkler piping. No more than 30% of the purlins can be altered or added.
 - ii. Three of the existing rigid frame columns require structural alterations. These columns are located at grids 2-C, 3-C and 4-B.
 - iii. The existing cross bracing in the south wall is inadequate. This will require the addition of another braced bay along the south wall or the replacement of the existing cross bracing with larger diameter rods.
 - iv. The existing K braced portal frame is inadequate. This will require replacement with a new portal frame or cross braced bay at grid B.
 - v. Two bays of roof plane cross bracing rods will be required at the lean-to roof.
 - vi. Bottom flange braces spaced at 10'-0" o.c. shall be added at the lean-to steel beams. These are the steel beams spanning from grid A to grid B.
 - b. An example of this increase would be new sprinkler piping supported from the roof with the tributary area of altered or new purlins less than 30% of the gross roof area.
 - c. Another allowable increase would be to replace the existing exterior walls with a light weight EIFS wall system.
4. If the seismic base shear is increased by more than 5 percent and more than 30 percent of the total roof area of the building is involved in structural alteration, the evaluation and analysis shall demonstrate that the altered building complies with the wind load and reduced IEBC seismic level forces in accordance with the IBC.
 - a. This category, in our opinion, will require more structural strengthening than is economically feasible for this project. Building replacement is our recommendation if the alterations meet these criteria.

The structural calculations are attached to this report in Appendix C.

RECOMMENDATIONS AND CONCLUSIONS

The following recommendations are the result of our field observations and results of analysis:

1. The structural alteration work to the roof framing members shall involve less than 30% of the gross roof area.
 - a. If a sprinkler system is installed and supported from the roof, new or altered roof purlins are required. The quantity of these new or altered purlins shall be less than 30% of the total roof purlins.
2. Additional vertical loads, beyond the sprinkler system, shall not be supported from the roof structure. This includes, but is not limited to, insulation, ceiling, soffits, mechanical equipment, etc.
3. A light weight EIFS system may be installed provided the framing support for this wall system is designed per the IBC. This wall system shall not create any parapets on the existing structure. New parapets will require the building to be in compliance with the IBC.
4. The following minimum structural strengthening recommendations shall be incorporated into the building:
 - i. New or altered purlins are required to support the sprinkler piping. No more than 30% of the existing purlins can be altered or added.
 - ii. Three of the existing rigid frame columns require structural alterations. This is anticipated to be the addition of steel plates on the existing column flanges. These columns are located at grids 2-C, 3-C and 4-B.
 - iii. The existing cross bracing in the south wall is inadequate. This will require the addition of another braced bay along the south wall or the replacement of the existing cross bracing with larger diameter rods.
 - iv. The existing K braced portal frame is inadequate. This will require replacement with a new portal frame(s) or cross braced bay(s) along grid B.
 - v. Two bays of roof plane cross bracing rods will be required at the lean-to roof.
 - vi. Bottom flange braces spaced at 10'-0" o.c. shall be added at the lean-to steel beams. These are the steel beams spanning from grid A to grid B.

We thank you for the opportunity to provide this structural analysis and report. The alterations and strengthening of the existing building will require construction documents prepared by a registered structural engineer. Please contact us if you have any questions regarding this report.

**APPENDIX A
FRAMING KEYPLAN**

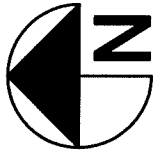
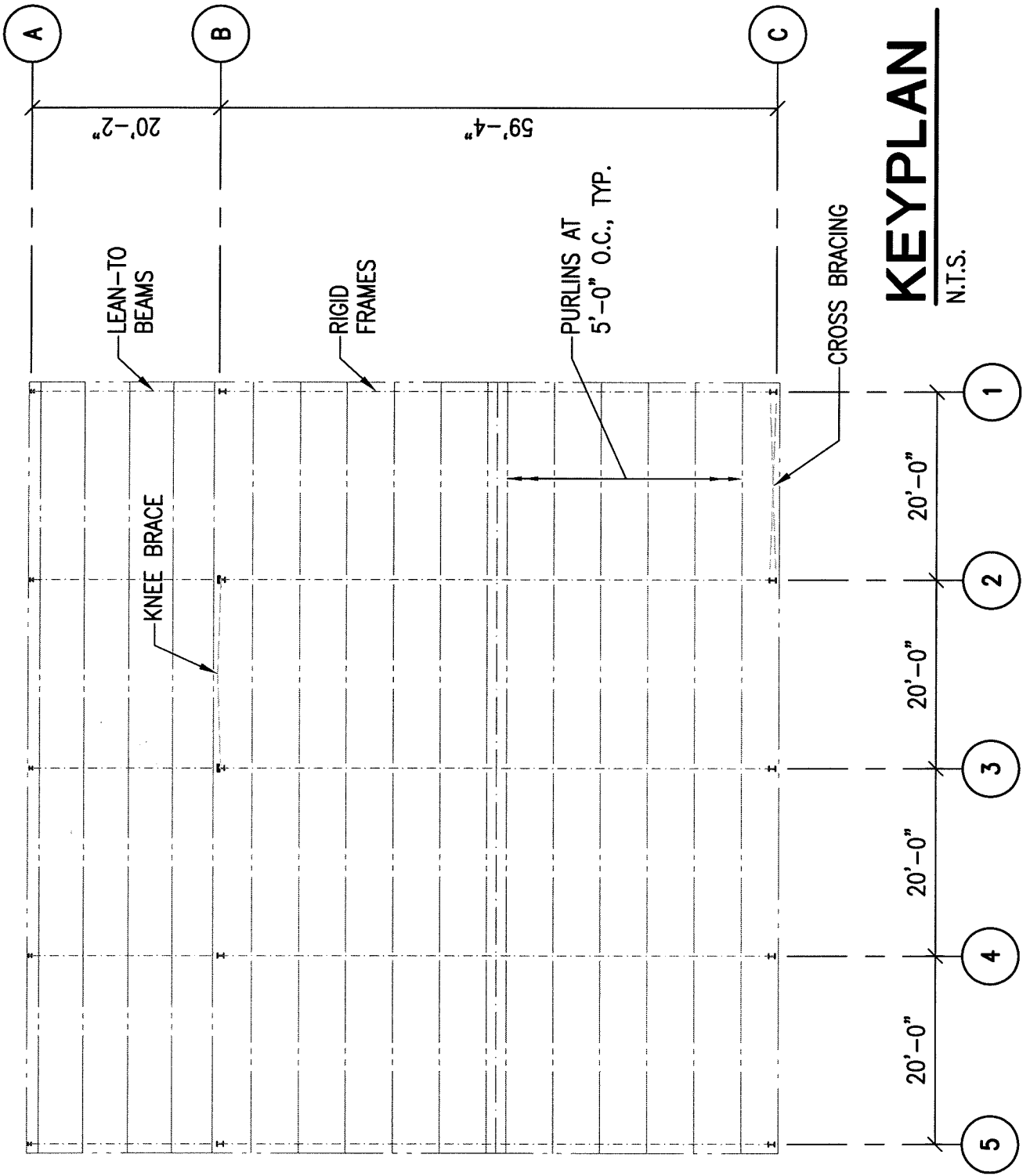

KEYPLAN
N.T.S.

APPENDIX B
MATERIAL PROPERTIES AS TESTED BY WESTERN TECHNOLOGIES INC.



Western Technologies Inc.
The Quality People
Since 1955

3737 East Broadway Road
Phoenix, Arizona 85040-2921
(602) 437-3737 • fax 470-1341

TENSION & BEND TESTS ON STEEL

Client **YUMA COUNTY AIRPORT AUTHORITY**
2191 E 32ND ST. STE 218
YUMA, AZ 85385

Date of Report **11-18-09**
Job No. **2169JE344**
Event / Invoice No. **C344-01**
Authorized By **CLIENT** Date **11-16-09**
Sampled By **CLIENT** Date **11-16-09**
Submitted By **CLIENT** Date **11-16-09**

Project **TENSILE TESTS**
Contractor **--**
Type / Use of Material **C/S**
Referenced Standard

Location **WT/PHX**
Arch. / Engr. **--**
Supplier / Source **--**

TEST DATA

SAMPLE NO.		1	2						
SIZE									
IDENTIFICATION		T1	T2						
MILL		-	-						
HEAT NO.		-	-						
LENGTH, IN.									
WEIGHT, PLF		-	-						
GRADE									
AREA, SQ. IN.		.1207	.2893						
YIELD POINT	LB	7,871	14,531						
	PSI	65,212	50,229						
TENSILE STRENGTH	LB	10,083	19,158						
	PSI	83,538	66,222						
GAUGE LENGTH, IN.		8"	8"						
FINAL LENGTH, IN.		9 5/16	9 11/16						
ELONGATION, %		17.5%	23%						
BEND TEST									
DIAMETER OF PIN									
DEGREE BENT									
MEETS REQUIREMENTS OF REFERENCED STANDARD	YES								
	NO								

Comments:

Copies To: **CLIENT (1)**

THE SERVICES REFERRED TO HEREIN WERE PERFORMED IN ACCORDANCE WITH THE STANDARD OF CARE PRACTICED LOCALLY FOR THE REFERENCED METHOD(S) AND RELATE ONLY TO THE CONDITION(S) OR SAMPLE(S) TESTED AS STATED HEREIN. WESTERN TECHNOLOGIES INC. MAKES NO OTHER WARRANTY OR REPRESENTATION, EXPRESS OR IMPLIED, AND HAS NOT CONFIRMED INFORMATION INCLUDING SOURCE OF MATERIALS SUBMITTED BY OTHERS.

REVIEWED BY: *Brendy Ferrar* 11-18-09

APPENDIX C
STRUCTURAL CALCULATIONS

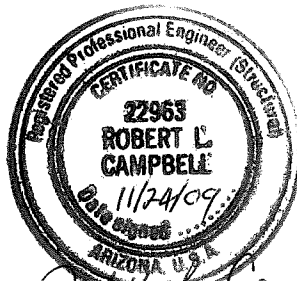

Robert L. Campbell

EXPIRES 6/30/11



LOADING CRITERIA

DEADLOAD

Roof Sheeting
Purlin Self Weight

1.5 PSF

0.6 PSF

= 2.1 PSF

COLLATERAL LOAD

Sprinkler

1.5 PSF

Live Load (ROOF)

20 PSF (reducible)

Load Case = DL + CL + LL_R

C2

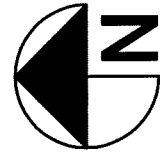

KEYPLAN
N.T.S.

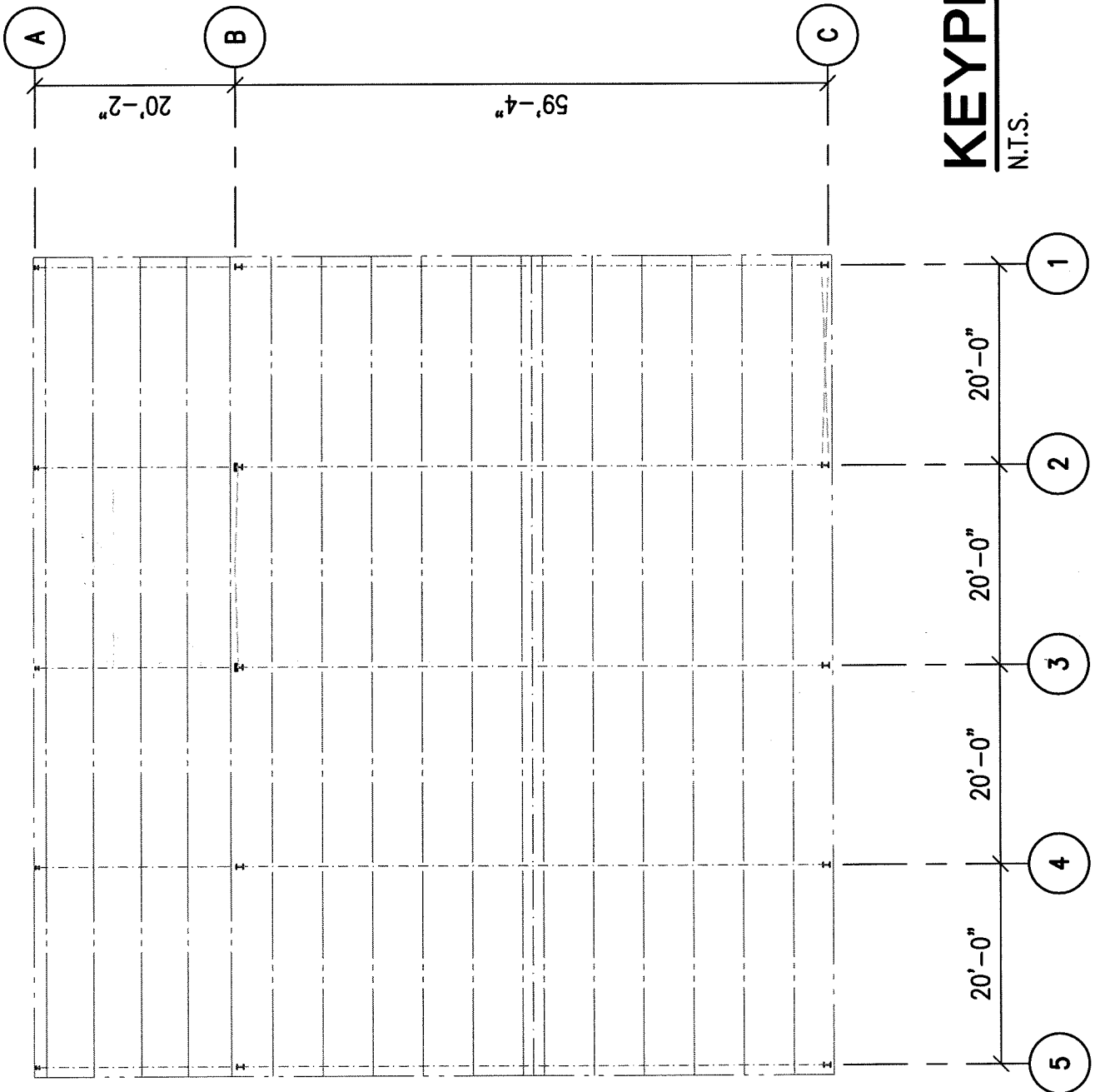



1985 WBC WIND AND SEISMIC CHECK

WIND PRESSURES

70 MPH EXP. 'C'

$$P = C_e C_g q_s I$$

$$q_s = 13 \text{ PSF}$$

$$C_e = 1.2$$

- $C_g = +0.8$ INWARD WINDWARD WALL
- $= -0.5$ OUTWARD LEEWARD WALL
- $= -0.7$ OUTWARD ROOF

$P = 13(1.2)(0.8)(1.0) = +12.5 \text{ PSF}$ WINDWARD WALL
 $P = 13(1.2)(0.5)(1.0) = -7.8 \text{ PSF}$ LEEWARD WALL
 $P = 13(1.2)(0.7)(1.0) = -10.9 \text{ PSF}$ ROOF

SEISMIC FORCES

$$V = Z I K C S W$$

↓ ZONE 4

$$V = (1)(1)(1)(0.14)W$$

$$V = 0.14W$$

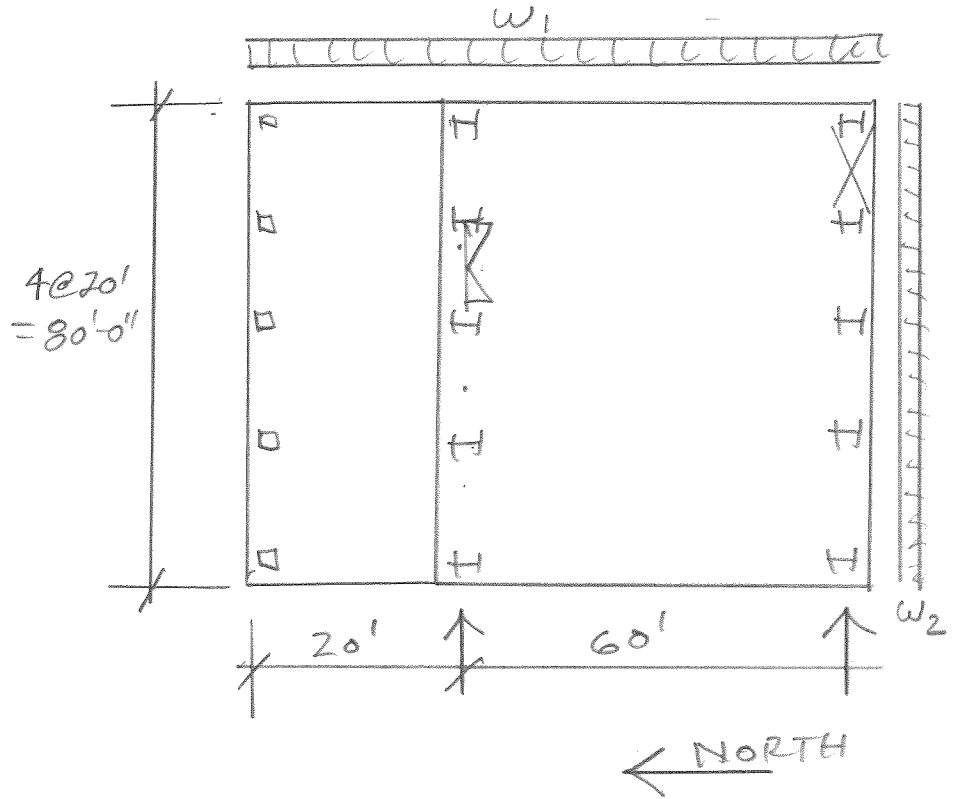

WIND FORCES:

$$w_1 = (12.5 + 7.8) \left(\frac{16}{2}\right) = 162 \text{ PLF GOVERNS}$$

$$w_2 = 12.5 \left(\frac{16}{2}\right) = 100 \text{ PLF GOVERNS}$$

SEISMIC FORCES

$$w_1 = 0.14 \left[\underset{\substack{\uparrow \text{DL} \\ + \text{SPRINK}}}{5.2} (80) + 8 \left(\frac{16}{2}\right) \right] = 76 \text{ PLF} < 162 \text{ PLF}$$

↓ EIFSWALL

$$w_2 = 0.14 \left[5.2 (80) + 8 \left(\frac{16}{2}\right) \right] = 67 \text{ PLF} < 100 \text{ PLF}$$



CHECK EXISTING 'X' BRACING IN S. WALL

$$F = 162(30) = 4.86 \text{ k}$$

$$R_{OD \text{ AXIAL}} = 4.86 \left(\frac{25.6}{20} \right) = 6.22 \text{ k}$$

$$A_{R_{OD \text{ REQ}}} = \frac{6.22}{19.1(1.33)} = 0.245 \text{ in}^2$$

$$\text{EXISTING } R_{OD} = 0.45" \phi = 0.16 \text{ in}^2$$

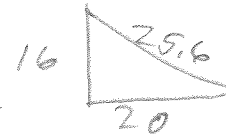
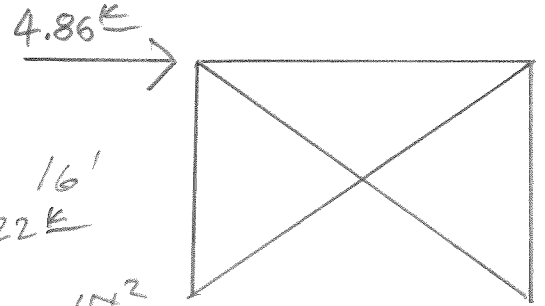

EXISTING ROD BRACE INADEQUATE



CHECK EXISTING KNEE BRACE FRAME

$$F = 162(50) = 8.1 \text{ K}$$

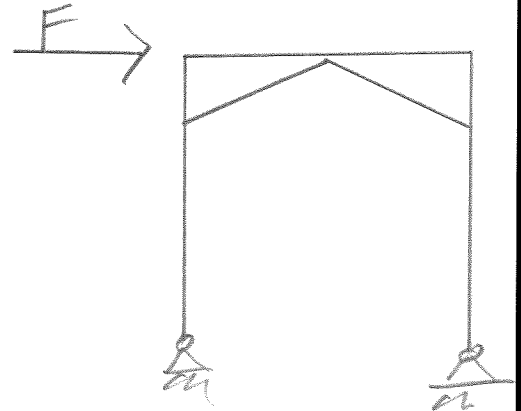

REF: PRINTOUT
FOR 1 K
LOADS

$$\text{AXIAL IN BRACE} = 3.0(8.1) = 24.3 \text{ K}$$

BOLTED CONNECTION = 2-5/8" ϕ BOLTS

$$\text{CONNECTION } P_a = 6.1(2)(1.33) = 16.2 \text{ K NOT ADEQUATE}$$

CHECK BENDING IN CHANNEL

SECTION PROPERTIES:

$$I = 58.8 \frac{\text{IN}^4}{\text{IN}}$$

$$S = 13.073 \frac{\text{IN}^3}{\text{IN}}$$

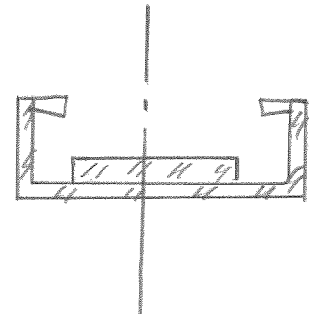

$$M = 8.1(6.0) = 48.6 \text{ K-FT}$$

$$f_b = \frac{48.6(12)}{13.1} = 44.5 \text{ KSI}$$

$$F_b = 0.6(50)(1.33) = 40 \text{ KSI}$$

11.5% OVERSTRESSED

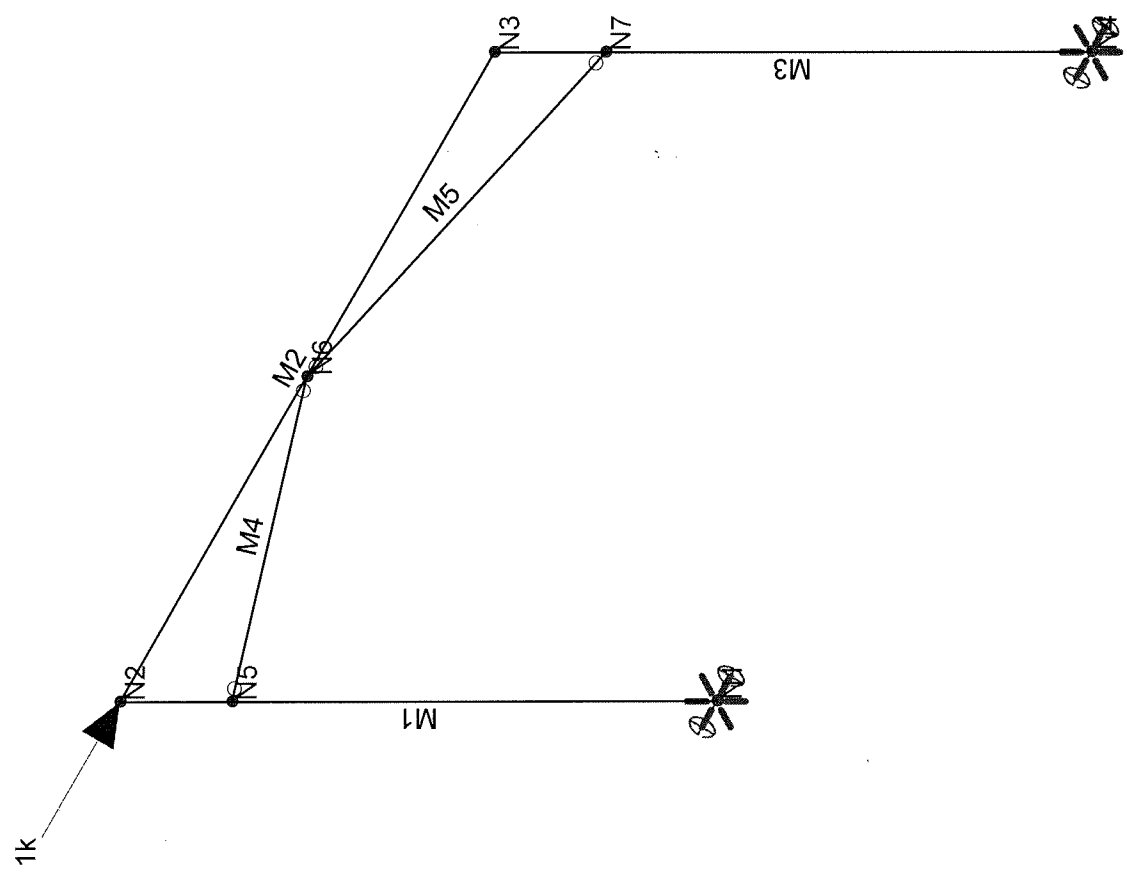
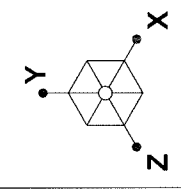

KNIFE BRACE

Loads: BLC 2, WL
Results for LC 2, WL

Robert L. Campbell Structural Engin..
KLB
09123

Nov 24, 2009 at 10:35 AM
MomentFrame.r3d

Weak Direction Frame

C8

Member Section Forces (By Combination)

	LC	Member Label	Sec	Axial[k]	y Shear[k]	z Shear[k]	Torque[k-ft]	y-y Moment[...]	z-z Moment[...]
1	2	M1	1	-8	.5	0	0	0	0
2			2	-8	.5	0	0	0	-1.999
3			3	-8	.5	0	0	0	-3.997
4			4	-8	.5	0	0	0	-5.996
5			5	.061	-2.37	0	0	0	.616
6	2	M2	1	3.37	.061	0	0	0	.616
7			2	3.37	.061	0	0	0	.311
8			3	3.37	.064	0	0	0	.006
9			4	-2.379	.064	0	0	0	-.314
10			5	-2.379	.064	0	0	0	-.633
11	2	M3	1	-.064	2.379	0	0	0	.633
12			2	.8	-.5	0	0	0	-6.004
13			3	.8	-.5	0	0	0	-4.003
14			4	.8	-.5	0	0	0	-2.001
15			5	.8	-.5	0	0	0	0
16	2	M4	1	-2.996	0	0	0	0	0
17			2	-2.996	0	0	0	0	0
18			3	-2.996	0	0	0	0	0
19			4	-2.996	0	0	0	0	0
20			5	-2.996	0	0	0	0	0
21	2	M5	1	3.006	0	0	0	0	0
22			2	3.006	0	0	0	0	0
23			3	3.006	0	0	0	0	0
24			4	3.006	0	0	0	0	0
25			5	3.006	0	0	0	0	0

MEMBER FORCES DUE TO
 1K LATERAL LOAD
 IN KNEE BRACE



PURLINS (HIGH BAY)

$$M_{ALLOW} = 66.01 \frac{1-L-R}{L} = 5.51 \frac{1-L-R}{L}$$

$$W_{ALLOW} = \frac{5.51 (8)}{(20)^2} = 0.11 \frac{1-L-R}{L}$$

$$ALLOW. UNIFORM LOAD = \frac{110}{5} = 22 \text{ PSF}$$

$$ROOF LIVE LOAD = 20 \text{ PSF}$$

$$ALLOWANCE DEAD LOAD = 2 \text{ PSF}$$

$$ACTUAL D.L. = 2.1 \text{ PSF}$$

REF: PRINTOUT

NO AVAILABLE COLLATERAL LOAD

PURLINS (LEAN TO)

REF: PRINTOUT

$$ALLOWABLE UNIFORM LOAD = 20.6 \text{ PSF}$$

NO AVAILABLE COLLATERAL LOAD

CFS Version 6.0.0
Section: Purlin P1.sct
Zee 8x2x0.5-14 Gage

C10

Rev. Date: 11/18/2009 12:47:54 PM
By: Robert L. Campbell, P.E., S.E.

Robert L. Campbell, P.E., S.E.
RLCSE
183 E. 24th Street Ste. 7
Yuma, AZ 85364
Ph: 928-726-2646, Fax: 928-726-2629
rob@campbellstructural.com

H160+BAY

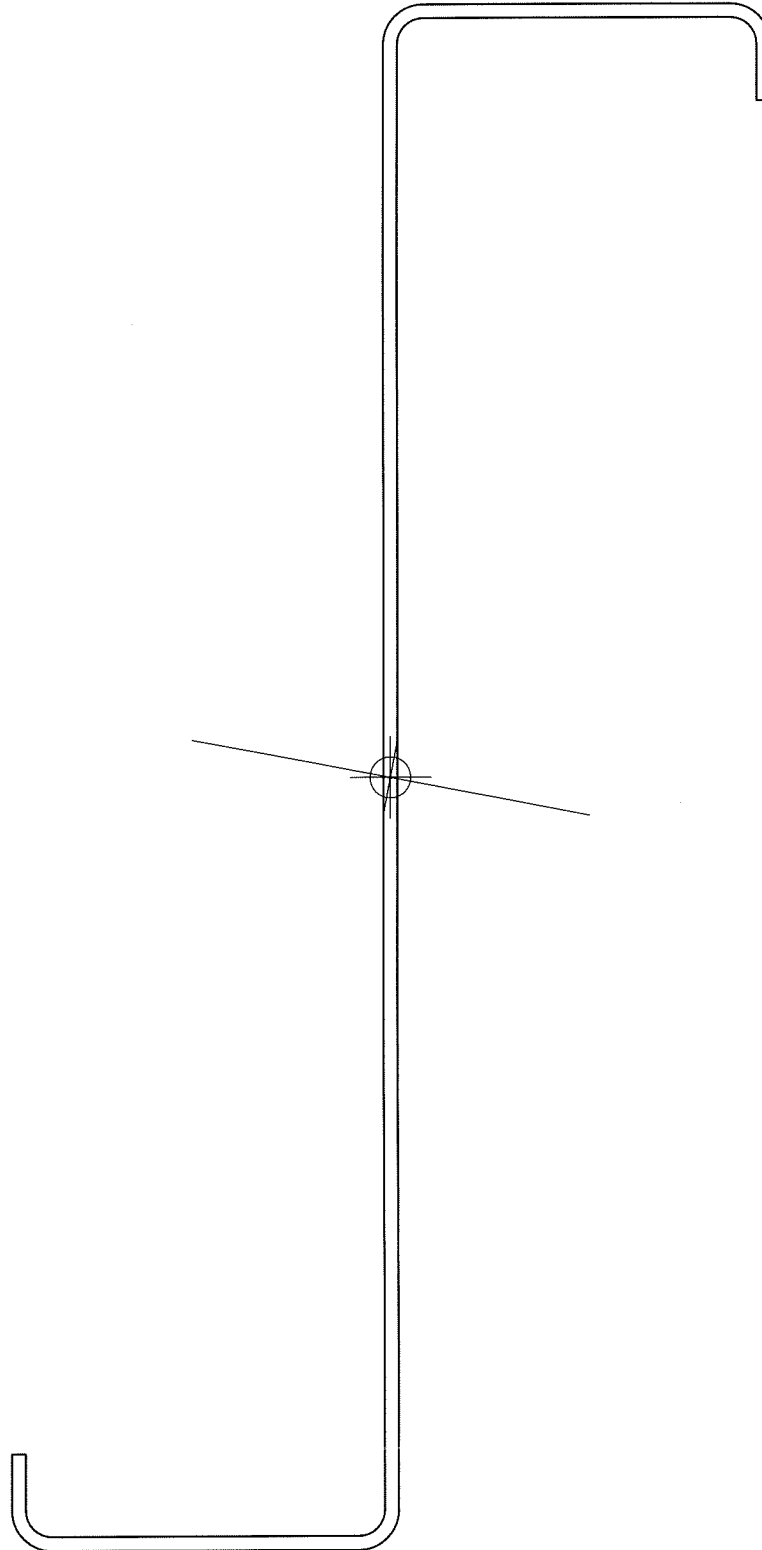

Section Inputs

C11

Section: Purlin P1.sct
Zee 8x2x0.5-14 Gage

Robert L. Campbell, P.E., S.E.
RLCSE
183 E. 24th Street Ste. 7
Yuma, AZ 85364
Ph: 928-726-2646, Fax: 928-726-2629
rob@campbellstructural.com

Rev. Date: 11/18/2009 12:47:54 PM
By: Robert L. Campbell, P.E., S.E.

Material: A653 HSLAS Grade 60
No strength increase from cold work of forming.
Modulus of Elasticity, E 29500 ksi
Yield Strength, Fy 60 ksi
Tensile Strength, Fu 70 ksi
Warping Constant Override, Cw 0 in⁶
Torsion Constant Override, J 0 in⁴

HIGH BAY

Stiffened Zee, Thickness 0.0713 in (14 Gage)

Placement of Part from Origin:

X to center of gravity 0 in
Y to center of gravity 0 in

Outside dimensions, Open shape

	Length (in)	Angle (deg)	Radius (in)	Web	k Coef.	Hole Size (in)	Distance (in)
1	0.5000	-90.000	0.13600	None	0.000	0.0000	0.2500
2	2.0000	0.000	0.13600	Single	0.000	0.0000	1.0000
3	8.0000	90.000	0.13600	Zee	0.000	0.0000	4.0000
4	2.0000	0.000	0.13600	Single	0.000	0.0000	1.0000
5	0.5000	-90.000	0.13600	None	0.000	0.0000	0.2500

Fully Braced Strength - 2001 North American Specification - US (ASD)

Material Type: A653 HSLAS Grade 60, Fy=60 ksi

Compression		Positive Moment		Positive Moment	
Pao	16.420 k	Maxo	66.097 k-in	Mayo	8.667 k-in
Ae	0.49261 in ²	Ixe	7.5435 in ⁴	Iye	0.4831 in ⁴
		Sxe(t)	1.8397 in ³	Sye(l)	0.2508 in ³
		Sxe(b)	1.9344 in ³	Sye(r)	0.2412 in ³
Tension		Negative Moment		Negative Moment	
Ta	30.994 k	Maxo	66.097 k-in	Mayo	8.667 k-in
		Ixe	7.5435 in ⁴	Iye	0.4831 in ⁴
		Sxe(t)	1.9344 in ³	Sye(l)	0.2412 in ³
		Sxe(b)	1.8397 in ³	Sye(r)	0.2508 in ³
Shear					
Vay	4.252 k				
Vax	5.087 k				

Full Section Properties

Area	0.88555 in ²	Wt.	0.0030109 k/ft	Width	12.420 in
Ix	7.8736 in ⁴	rx	2.9818 in	Ixy	1.4473 in ⁴
Sx(t)	1.9684 in ³	y(t)	4.0000 in	α	-10.780 deg
Sx(b)	1.9684 in ³	y(b)	4.0000 in		
		Height	8.0000 in		
Iy	0.5476 in ⁴	ry	0.7864 in	Xo	0.0000 in
Sy(l)	0.2788 in ³	x(l)	1.9643 in	Yo	0.0000 in
Sy(r)	0.2788 in ³	x(r)	1.9643 in	jx	0.0000 in
		Width	3.9287 in	jy	0.0000 in
I1	8.1492 in ⁴	r1	3.0335 in		
I2	0.2721 in ⁴	r2	0.5543 in		
Ic	8.4213 in ⁴	rc	3.0838 in	Cw	6.4776 in ⁶
Io	8.4213 in ⁴	ro	3.0838 in	J	0.0015006 in ⁴

Rev. Date: 11/18/2009 1:16:00 PM
 By: Robert L. Campbell, P.E., S.E.

Robert L. Campbell, P.E., S.E.
 RLCSE
 183 E. 24th Street Ste. 7
 Yuma, AZ 85364
 Ph: 928-726-2646, Fax: 928-726-2629
 rob@campbellstructural.com

Material: A653 HSLAS Grade 60
 No strength increase from cold work of forming.
 Modulus of Elasticity, E 29500 ksi
 Yield Strength, Fy 60 ksi
 Tensile Strength, Fu 70 ksi
 Warping Constant Override, Cw 0 in⁶
 Torsion Constant Override, J 0 in⁴

PURLINS AT
LEAN TO

Stiffened Zee, Thickness 0.0713 in (14 Gage)

Placement of Part from Origin:

X to center of gravity 0 in
 Y to center of gravity 0 in

Outside dimensions, Open shape

	Length (in)	Angle (deg)	Radius (in)	Web	k Coef.	Hole Size (in)	Distance (in)
1	0.7500	-90.000	0.13600	None	0.000	0.0000	0.3750
2	2.5000	0.000	0.13600	Single	0.000	0.0000	1.2500
3	7.0000	90.000	0.13600	Zee	0.000	0.0000	3.5000
4	2.5000	0.000	0.13600	Single	0.000	0.0000	1.2500
5	0.7500	-90.000	0.13600	None	0.000	0.0000	0.3750

Full Section Properties

Area	0.92120 in ²	Wt.	0.0031321 k/ft	Width	12.920 in
Ix	6.8654 in ⁴	rx	2.7300 in	Ixy	2.1368 in ⁴
Sx(t)	1.9616 in ³	y(t)	3.5000 in	α	-18.560 deg
Sx(b)	1.9616 in ³	y(b)	3.5000 in		
		Height	7.0000 in		
Iy	1.2190 in ⁴	ry	1.1503 in	Xo	0.0000 in
Sy(l)	0.4946 in ³	x(l)	2.4643 in	Yo	0.0000 in
Sy(r)	0.4946 in ³	x(r)	2.4643 in	jx	0.0000 in
		Width	4.9287 in	jy	0.0000 in
I1	7.5829 in ⁴	r1	2.8691 in		
I2	0.5015 in ⁴	r2	0.7379 in		
Ic	8.0844 in ⁴	rc	2.9624 in	Cw	10.360 in ⁶
Io	8.0844 in ⁴	ro	2.9624 in	J	0.001561 in ⁴

Fully Braced Strength - 2001 North American Specification - US (ASD)

Material Type: A653 HSLAS Grade 60, Fy=60 ksi

Compression		Positive Moment		Positive Moment	
Pao	18.160 k	Maxo	61.870 k-in	Mayo	13.826 k-in
Ae	0.54481 in ²	Ixe	6.3364 in ⁴	Iye	0.9911 in ⁴
		Sxe(t)	1.7220 in ³	Sye(l)	0.4212 in ³
		Sxe(b)	1.9083 in ³	Sye(r)	0.3848 in ³
Tension		Negative Moment		Negative Moment	
Ta	32.242 k	Maxo	61.870 k-in	Mayo	13.826 k-in
		Ixe	6.3364 in ⁴	Iye	0.9911 in ⁴
Shear		Sxe(t)	1.9083 in ³	Sye(l)	0.3848 in ³
Vay	4.898 k	Sxe(b)	1.7220 in ³	Sye(r)	0.4212 in ³
Vax	6.691 k				

Allow = 70.6 ^{P9F}



BEAM / COLUMN HAUNCH

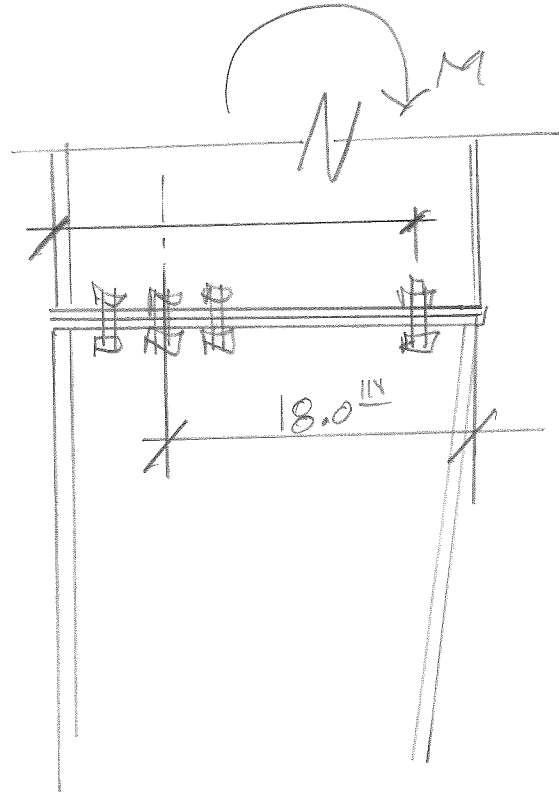

6 - 3/4" ϕ A325

$$T_a / \text{BOLT} = 19.4 \text{ K}$$

$$+ M_a = \frac{19.4(6)(18)}{12} = 175 \text{ 1-K}$$

$$- M_a = \frac{19.4(2)(23.75)}{(12)} = 76.8 \text{ 1-K}$$

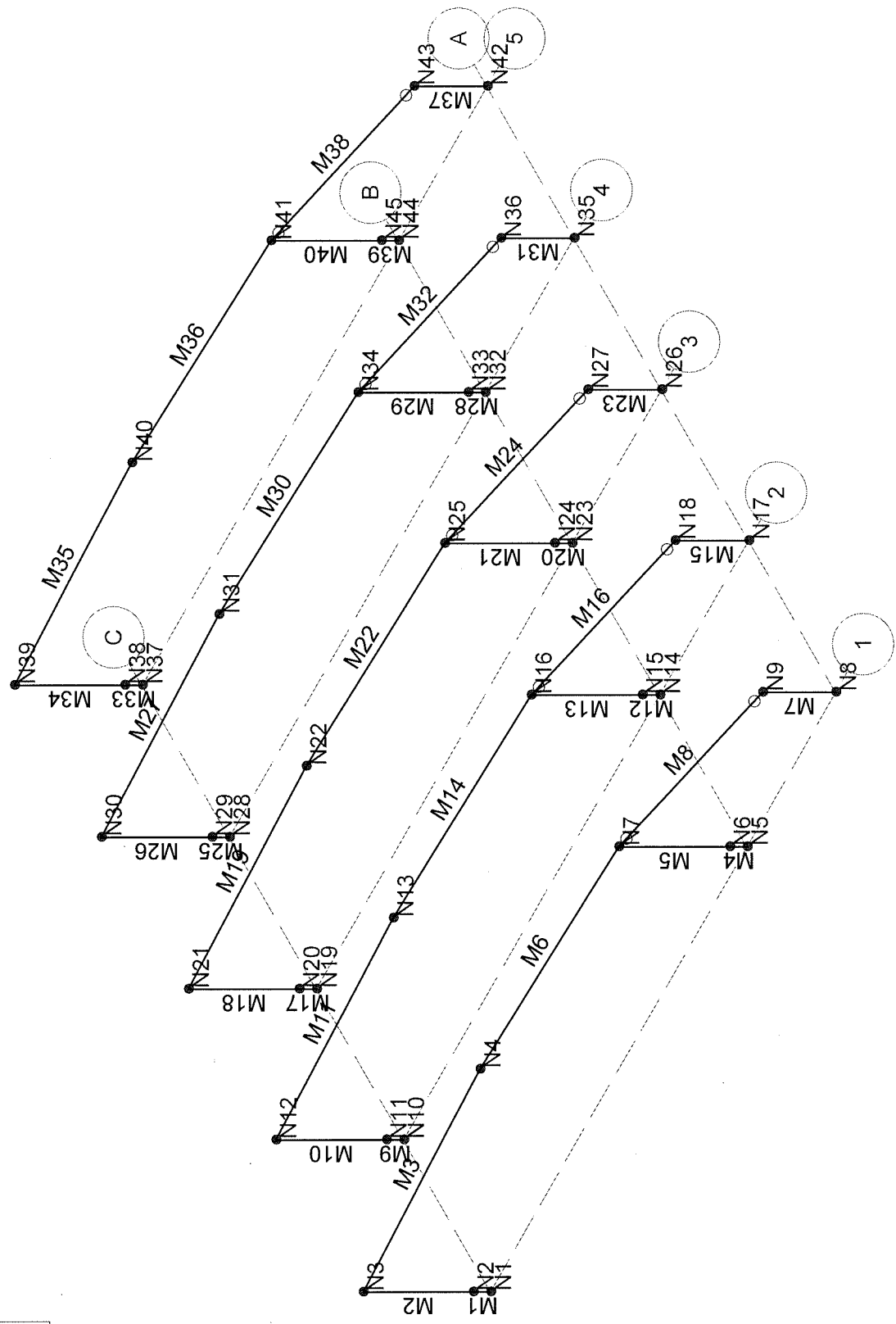
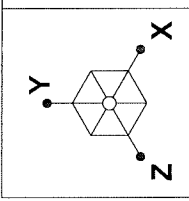

Robert L. Campbell Structural Engin...
 KLB
 09123

BET-KO Air
 Node and Member Locations

Nov 24, 2009 at 2:39 PM
 Grid1-50ksi.r3d

C15

Company : Robert L. Campbell Structural Engineer, PC
Designer : KLB
Job Number : 09123

BET-KO Air

Nov 24, 2009
2:49 PM
Checked By: _____

Load Combinations

	Description	Solve	PDelta	SRSS	BLC Factor	BLC Factor	BLC Factor	BLC Factor	BLC Factor	BLC Factor	BLC Factor	BLC Factor	BLC Factor	BLC Factor	BLC Factor	BLC Factor	BLC Factor	BLC Factor	
1	DL	Yes			DL	1													
2	DL+LLr (Existing)	Yes			DL	1	RLL	1											
3	DL+CL+LLr (Pr...	Yes			DL	1	OL1	1	RLL	1									

→ This Evaluation

C16

Member AISC ASD Steel Code Checks (By Combination)

L	Member	Shape	UC Max	Loc	Shea	Loc	Fa[ksi]	Ft[ksi]	Fby[ksi]	Fbz[ksi]	Cb	Cmy	Cmz	Eqn		
1	3	M1	Col_C1..	.234	2	.073	0	y	27.448	30	32.537	22.367	1.75	.6	.6	H1-2
2	3	M2	Col_C1..	.602	8.841	.088	12....	y	23.324	30	27.509	12.847	1....	.994	1	AF14
3	3	M3	Frame...	- Taper Comp. flange < Tension flange, per A...												
4	3	M4	Col_B1..	.132	2	.071	0	y	19.931	30	37.5	30	1.75	.6	.6	H2-1
5	3	M5	Col_B1..	.354	8.313	.087	12....	y	19.931	30	37.5	18.022	1....	.961	1	H2-1
6	3	M6	Frame...	- Taper Comp. flange < Tension flange, per A...												
7	3	M7	Col_Gri..	.033	0	.000	0	z	15.483	21.6	27	21.6	1.75	.6	.6	H1-1
8	3	M8	W10X15	.372	10....	.053	21....	y	15.997	21.6	27	21.6	1	.6	1	H1-1
9	3	M9	Col_C1..	.440	2	.138	0	y	27.448	30	32.537	22.367	1.75	.6	.6	H1-2
10	3	M10	Col_C1..	1.135	8.841	.166	12....	y	23.324	30	27.509	12.847	1....	.99	1	AF14
11	3	M11	Frame...	- Taper Comp. flange < Tension flange, per A...												
12	3	M12	Col_B2..	.181	2	.131	0	y	29.262	30	37.5	33	1.75	.6	.6	H1-2
13	3	M13	Col_B2..	.416	0	.151	12....	y	22.218	30	37.5	21.888	1....	.961	1	AF14
14	3	M14	Frame...	- Taper Comp. flange < Tension flange, per A...												
15	3	M15	Col_Gri..	.061	0	.000	0	z	15.483	21.6	27	21.6	1.75	.6	.6	H1-1
16	3	M16	W10X15	.712	10....	.100	21....	y	15.997	21.6	27	21.6	1	.6	1	H2-1
17	3	M17	Col_C1..	.440	2	.138	0	y	27.448	30	32.537	22.367	1.75	.6	.6	H1-2
18	3	M18	Col_C1..	1.135	8.841	.166	12....	y	23.324	30	27.509	12.847	1....	.99	1	AF14
19	3	M19	Frame...	- Taper Comp. flange < Tension flange, per A...												
20	3	M20	Col_B2..	.193	2	.131	0	y	20.407	30	37.5	30	1.75	.6	.6	H1-2
21	3	M21	Col_B2..	.480	0	.151	12....	y	20.407	30	37.5	18.724	1....	.949	1	AF14
22	3	M22	Frame...	- Taper Comp. flange < Tension flange, per A...												
23	3	M23	Col_Gri..	.061	0	.000	0	z	15.483	21.6	27	21.6	1.75	.6	.6	H1-1
24	3	M24	W10X15	.712	10....	.100	21....	y	15.997	21.6	27	21.6	1	.6	1	H2-1
25	3	M25	Col_C4..	.218	2	.130	0	y	29.23	30	37.5	33	1.75	.6	.6	H2-1
26	3	M26	Col_C4..	.666	8.577	.162	12....	y	25.255	30	37.5	17.777	1....	.994	1	H2-1
27	3	M27	Frame...	- Taper Comp. flange < Tension flange, per A...												
28	3	M28	Col_B4..	.601	2	.140	2	y	18.912	30	32.537	18.894	1.75	.891	1	AF12
29	3	M29	Col_B4..	1.208	0	.163	12....	y	18.879	30	32.537	12.846	1....	.891	1	AF12
30	3	M30	Frame...	- Taper Comp. flange < Tension flange, per A...												
31	3	M31	Col_Gri..	.061	0	.000	0	z	15.483	21.6	27	21.6	1.75	.6	.6	H1-1
32	3	M32	W10X15	.712	10....	.100	21....	y	15.997	21.6	27	21.6	1	.6	1	H1-1
33	3	M33	Col_C5..	.222	2	.072	0	y	27.448	30	33.274	23.172	1.75	.6	.6	H1-2
34	3	M34	Col_C5..	.586	8.841	.083	12....	y	23.648	30	27.952	12.888	1....	.994	1	AF14
35	3	M35	Frame...	- Taper Comp. flange < Tension flange, per A...												
36	3	M36	Frame...	- Taper Comp. flange < Tension flange, per A...												
37	3	M37	Col_Gri..	.033	0	.000	0	z	15.483	21.6	27	21.6	1.75	.6	.6	H1-1
38	3	M38	W10X15	.372	10....	.053	21....	y	15.997	21.6	27	21.6	1	.6	1	H1-1
39	3	M39	Col_B5..	.131	2	.068	0	y	19.845	30	37.5	30	1.75	.6	.6	H2-1
40	3	M40	Col_B5..	.350	8.181	.075	12....	y	19.845	30	37.5	17.949	1....	.961	1	H2-1

C17

Company : Robert L. Campbell Structural Engineer, PC
 Designer : KLB
 Job Number : 09123

BET-KO Air

Nov 24, 2009
 2:48 PM
 Checked By: _____

Joint Reactions (By Combination)

	LC	Joint Label	X [k]	Y [k]	Z [k]	MX [k-ft]	MY [k-ft]	MZ [k-ft]
1	3	N1	2.341	5.593	0	0	0	0
2	3	N5	-2.341	7.507	0	0	0	0
3	3	N8	0	1.928	0	0	0	0
4	3	N10	4.431	10.172	0	0	0	0
5	3	N14	-4.431	13.838	0	0	0	0
6	3	N17	0	3.587	0	0	0	0
7	3	N19	4.431	10.172	0	0	0	0
8	3	N23	-4.431	13.838	0	0	0	0
9	3	N26	0	3.587	0	0	0	0
10	3	N28	4.355	10.266	0	0	0	0
11	3	N32	-4.355	13.65	0	0	0	0
12	3	N35	0	3.587	0	0	0	0
13	3	N37	2.347	5.598	0	0	0	0
14	3	N42	0	1.928	0	0	0	0
15	3	N44	-2.347	7.514	0	0	0	0
16	3	Totals:	0	112.765	0			
17	3	COG (ft):	X: 39.555	Y: 14.117	Z: 40.012			

C17

Member Section Forces (By Combination)

	LC	Member Label	Sec	Axial[k]	y Shear[k]	z Shear[k]	Torque[k-ft]	y-y Moment[...]	z-z Moment[...]
1	3	M1	1	5.593	-2.341	0	0	0	0
2			2	5.585	-2.341	0	0	0	1.171
3			3	5.577	-2.341	0	0	0	2.341
4			4	5.57	-2.341	0	0	0	3.512
5			5	5.562	-2.341	0	0	0	4.683
6	3	M2	1	5.562	-2.341	0	0	0	4.683
7			2	5.509	-2.341	0	0	0	12.097
8			3	5.446	-2.341	0	0	0	19.512
9			4	5.373	-2.341	0	0	0	26.927
10			5	5.29	-2.341	0	0	0	34.341
11	3	M3	1	2.56	5.188	0	0	0	34.341
12			2	2.506	3.892	0	0	0	1.008
13			3	2.451	2.579	0	0	0	-22.751
14			4	2.395	1.249	0	0	0	-36.811
15			5	2.339	-.097	0	0	0	-41.048
16	3	M4	1	7.507	-2.341	0	0	0	0
17			2	7.496	-2.341	0	0	0	1.171
18			3	7.485	-2.341	0	0	0	2.341
19			4	7.474	-2.341	0	0	0	3.512
20			5	7.463	-2.341	0	0	0	4.683
21	3	M5	1	7.463	-2.341	0	0	0	4.683
22			2	7.389	-2.341	0	0	0	12.097
23			3	7.305	-2.341	0	0	0	19.512
24			4	7.212	-2.341	0	0	0	26.927
25			5	7.109	-2.341	0	0	0	34.341
26	3	M6	1	2.56	5.188	0	0	0	34.341
27			2	2.506	3.892	0	0	0	1.008
28			3	2.451	2.579	0	0	0	-22.751
29			4	2.395	1.249	0	0	0	-36.811
30			5	2.339	-.097	0	0	0	-41.048
31	3	M7	1	1.928	0	0	0	0	0
32			2	1.901	0	0	0	0	0
33			3	1.873	0	0	0	0	0
34			4	1.846	0	0	0	0	0
35			5	1.819	0	0	0	0	0
36	3	M8	1	-.534	1.739	0	0	0	0
37			2	-.267	.869	0	0	0	-6.935
38			3	0	0	0	0	0	-9.246
39			4	.267	-.869	0	0	0	-6.935
40			5	.534	-1.739	0	0	0	0
41	3	M9	1	10.172	-4.431	0	0	0	0
42			2	10.165	-4.431	0	0	0	2.215
43			3	10.157	-4.431	0	0	0	4.431
44			4	10.149	-4.431	0	0	0	6.646
45			5	10.142	-4.431	0	0	0	8.862
46	3	M10	1	10.142	-4.431	0	0	0	8.862
47			2	10.088	-4.431	0	0	0	22.893
48			3	10.025	-4.431	0	0	0	36.924
49			4	9.953	-4.431	0	0	0	50.956
50			5	9.87	-4.431	0	0	0	64.987
51	3	M11	1	4.838	9.677	0	0	0	64.987
52			2	4.736	7.237	0	0	0	2.904
53			3	4.634	4.78	0	0	0	-41.207
54			4	4.531	2.306	0	0	0	-67.223
55			5	4.427	-.184	0	0	0	-75.02
56	3	M12	1	13.838	-4.431	0	0	0	0

Member Section Forces (By Combination) (Continued)

	LC	Member Label	Sec	Axial[k]	y Shear[k]	z Shear[k]	Torque[k-ft]	y-y Moment[...]	z-z Moment[...]
57			2	13.824	-4.431	0	0	0	2.215
58			3	13.81	-4.431	0	0	0	4.431
59			4	13.796	-4.431	0	0	0	6.646
60			5	13.782	-4.431	0	0	0	8.862
61	3	M13	1	13.782	-4.431	0	0	0	8.862
62			2	13.688	-4.431	0	0	0	22.893
63			3	13.585	-4.431	0	0	0	36.924
64			4	13.471	-4.431	0	0	0	50.956
65			5	13.348	-4.431	0	0	0	64.987
66	3	M14	1	4.838	9.677	0	0	0	64.987
67			2	4.736	7.237	0	0	0	2.904
68			3	4.634	4.78	0	0	0	-41.207
69			4	4.531	2.306	0	0	0	-67.223
70			5	4.427	-.184	0	0	0	-75.02
71	3	M15	1	3.587	0	0	0	0	0
72			2	3.56	0	0	0	0	0
73			3	3.533	0	0	0	0	0
74			4	3.505	0	0	0	0	0
75			5	3.478	0	0	0	0	0
76	3	M16	1	-1.022	3.325	0	0	0	0
77			2	-.511	1.662	0	0	0	-13.261
78			3	0	0	0	0	0	-17.681
79			4	.511	-1.662	0	0	0	-13.261
80			5	1.022	-3.325	0	0	0	0
81	3	M17	1	10.172	-4.431	0	0	0	0
82			2	10.165	-4.431	0	0	0	2.215
83			3	10.157	-4.431	0	0	0	4.431
84			4	10.149	-4.431	0	0	0	6.646
85			5	10.142	-4.431	0	0	0	8.862
86	3	M18	1	10.142	-4.431	0	0	0	8.862
87			2	10.088	-4.431	0	0	0	22.893
88			3	10.025	-4.431	0	0	0	36.924
89			4	9.953	-4.431	0	0	0	50.956
90			5	9.87	-4.431	0	0	0	64.987
91	3	M19	1	4.838	9.677	0	0	0	64.987
92			2	4.736	7.237	0	0	0	2.904
93			3	4.634	4.78	0	0	0	-41.207
94			4	4.531	2.306	0	0	0	-67.223
95			5	4.427	-.184	0	0	0	-75.02
96	3	M20	1	13.838	-4.431	0	0	0	0
97			2	13.824	-4.431	0	0	0	2.215
98			3	13.81	-4.431	0	0	0	4.431
99			4	13.796	-4.431	0	0	0	6.646
100			5	13.782	-4.431	0	0	0	8.862
101	3	M21	1	13.782	-4.431	0	0	0	8.862
102			2	13.688	-4.431	0	0	0	22.893
103			3	13.585	-4.431	0	0	0	36.924
104			4	13.471	-4.431	0	0	0	50.956
105			5	13.348	-4.431	0	0	0	64.987
106	3	M22	1	4.838	9.677	0	0	0	64.987
107			2	4.736	7.237	0	0	0	2.904
108			3	4.634	4.78	0	0	0	-41.207
109			4	4.531	2.306	0	0	0	-67.223
110			5	4.427	-.184	0	0	0	-75.02
111	3	M23	1	3.587	0	0	0	0	0
112			2	3.56	0	0	0	0	0
113			3	3.533	0	0	0	0	0

Member Section Forces (By Combination) (Continued)

	LC	Member Label	Sec	Axial[k]	v Shear[k]	z Shear[k]	Torque[k-ft]	y-y Momentf...	z-z Momentf...
114			4	3.505	0	0	0	0	0
115			5	3.478	0	0	0	0	0
116	3	M24	1	-1.022	3.325	0	0	0	0
117			2	-.511	1.662	0	0	0	-13.261
118			3	0	0	0	0	0	-17.681
119			4	.511	-1.662	0	0	0	-13.261
120			5	1.022	-3.325	0	0	0	0
121	3	M25	1	10.266	-4.355	0	0	0	0
122			2	10.255	-4.355	0	0	0	2.177
123			3	10.244	-4.355	0	0	0	4.355
124			4	10.233	-4.355	0	0	0	6.532
125			5	10.222	-4.355	0	0	0	8.709
126	3	M26	1	10.222	-4.355	0	0	0	8.709
127			2	10.148	-4.355	0	0	0	22.499
128			3	10.065	-4.355	0	0	0	36.289
129			4	9.972	-4.355	0	0	0	50.08
130			5	9.87	-4.355	0	0	0	63.87
131	3	M27	1	4.762	9.68	0	0	0	63.87
132			2	4.66	7.24	0	0	0	1.763
133			3	4.558	4.783	0	0	0	-42.371
134			4	4.455	2.309	0	0	0	-68.411
135			5	4.351	-.181	0	0	0	-76.231
136	3	M28	1	13.65	-4.355	0	0	0	0
137			2	13.642	-4.355	0	0	0	2.177
138			3	13.635	-4.355	0	0	0	4.355
139			4	13.627	-4.355	0	0	0	6.532
140			5	13.619	-4.355	0	0	0	8.709
141	3	M29	1	13.619	-4.355	0	0	0	8.709
142			2	13.566	-4.355	0	0	0	22.499
143			3	13.503	-4.355	0	0	0	36.289
144			4	13.431	-4.355	0	0	0	50.08
145			5	13.348	-4.355	0	0	0	63.87
146	3	M30	1	4.762	9.68	0	0	0	63.87
147			2	4.66	7.24	0	0	0	1.763
148			3	4.558	4.783	0	0	0	-42.371
149			4	4.455	2.309	0	0	0	-68.411
150			5	4.351	-.181	0	0	0	-76.231
151	3	M31	1	3.587	0	0	0	0	0
152			2	3.56	0	0	0	0	0
153			3	3.533	0	0	0	0	0
154			4	3.505	0	0	0	0	0
155			5	3.478	0	0	0	0	0
156	3	M32	1	-1.022	3.325	0	0	0	0
157			2	-.511	1.662	0	0	0	-13.261
158			3	0	0	0	0	0	-17.681
159			4	.511	-1.662	0	0	0	-13.261
160			5	1.022	-3.325	0	0	0	0
161	3	M33	1	5.598	-2.347	0	0	0	0
162			2	5.59	-2.347	0	0	0	1.173
163			3	5.583	-2.347	0	0	0	2.347
164			4	5.575	-2.347	0	0	0	3.52
165			5	5.567	-2.347	0	0	0	4.693
166	3	M34	1	5.567	-2.347	0	0	0	4.693
167			2	5.513	-2.347	0	0	0	12.125
168			3	5.448	-2.347	0	0	0	19.556
169			4	5.374	-2.347	0	0	0	26.988
170			5	5.29	-2.347	0	0	0	34.419

Member Section Forces (By Combination) (Continued)

	LC	Member Label	Sec	Axial[k]	y Shear[k]	z Shear[k]	Torque[k-ft]	y-y Moment[...]	z-z Moment[...]
171	3	M35	1	2.565	5.188	0	0	0	34.419
172			2	2.511	3.892	0	0	0	1.087
173			3	2.456	2.579	0	0	0	-22.67
174			4	2.401	1.249	0	0	0	-36.729
175			5	2.345	-.098	0	0	0	-40.964
176	3	M36	1	2.565	5.188	0	0	0	34.419
177			2	2.511	3.892	0	0	0	1.087
178			3	2.456	2.579	0	0	0	-22.67
179			4	2.401	1.249	0	0	0	-36.729
180			5	2.345	-.098	0	0	0	-40.964
181	3	M37	1	1.928	0	0	0	0	0
182			2	1.901	0	0	0	0	0
183			3	1.873	0	0	0	0	0
184			4	1.846	0	0	0	0	0
185			5	1.819	0	0	0	0	0
186	3	M38	1	-.534	1.739	0	0	0	0
187			2	-.267	.869	0	0	0	-6.935
188			3	0	0	0	0	0	-9.246
189			4	.267	-.869	0	0	0	-6.935
190			5	.534	-1.739	0	0	0	0
191	3	M39	1	7.514	-2.347	0	0	0	0
192			2	7.503	-2.347	0	0	0	1.173
193			3	7.492	-2.347	0	0	0	2.347
194			4	7.481	-2.347	0	0	0	3.52
195			5	7.47	-2.347	0	0	0	4.693
196	3	M40	1	7.47	-2.347	0	0	0	4.693
197			2	7.395	-2.347	0	0	0	12.125
198			3	7.31	-2.347	0	0	0	19.556
199			4	7.214	-2.347	0	0	0	26.988
200			5	7.109	-2.347	0	0	0	34.419

Member Section Stresses (By Combination)

	LC	Member Label	Sec	Axial[ksi]	y Shear[ksi]	z Shear[ksi]	y top Bendin...	y bot Bendin...	z top Bendin...	z bot Bendin...
1	3	M1	1	1.243	-1.463	0	0	0	0	0
2			2	1.241	-1.463	0	-1.079	1.079	0	0
3			3	1.239	-1.463	0	-2.157	2.157	0	0
4			4	1.238	-1.463	0	-3.236	3.236	0	0
5			5	1.236	-1.463	0	-4.315	4.315	0	0
6	3	M2	1	1.236	-1.463	0	-4.315	4.315	0	0
7			2	1.02	-.937	0	-6.418	6.418	0	0
8			3	.864	-.689	0	-6.976	6.976	0	0
9			4	.746	-.545	0	-7.045	7.045	0	0
10			5	.653	-.45	0	-6.925	6.925	0	0
11	3	M3	1	.444	1.918	0	-14.308	15.022	0	0
12			2	.389	1.151	0	-.316	.331	0	0
13			3	.345	.636	0	5.633	-5.863	0	0
14			4	.308	.264	0	7.421	-7.698	0	0
15			5	.276	-.018	0	6.899	-7.136	0	0
16	3	M4	1	1.168	-1.419	0	0	0	0	0
17			2	1.166	-1.419	0	-.987	.576	0	0
18			3	1.164	-1.419	0	-1.975	1.152	0	0
19			4	1.162	-1.419	0	-2.962	1.728	0	0
20			5	1.161	-1.419	0	-3.95	2.304	0	0
21	3	M5	1	1.161	-1.419	0	-3.95	2.304	0	0
22			2	1.01	-.923	0	-5.846	3.582	0	0
23			3	.89	-.684	0	-6.319	4.057	0	0
24			4	.793	-.543	0	-6.359	4.25	0	0
25			5	.712	-.45	0	-6.238	4.314	0	0
26	3	M6	1	.444	1.918	0	-14.308	15.022	0	0
27			2	.389	1.151	0	-.316	.331	0	0
28			3	.345	.636	0	5.633	-5.863	0	0
29			4	.308	.264	0	7.421	-7.698	0	0
30			5	.276	-.018	0	6.899	-7.136	0	0
31	3	M7	1	.506	0	0	0	0	0	0
32			2	.499	0	0	0	0	0	0
33			3	.491	0	0	0	0	0	0
34			4	.484	0	0	0	0	0	0
35			5	.477	0	0	0	0	0	0
36	3	M8	1	-.121	.757	0	0	0	0	0
37			2	-.061	.378	0	6.033	-6.033	0	0
38			3	0	0	0	8.044	-8.044	0	0
39			4	.061	-.378	0	6.033	-6.033	0	0
40			5	.121	-.757	0	0	0	0	0
41	3	M9	1	2.261	-2.769	0	0	0	0	0
42			2	2.259	-2.769	0	-2.041	2.041	0	0
43			3	2.257	-2.769	0	-4.083	4.083	0	0
44			4	2.255	-2.769	0	-6.124	6.124	0	0
45			5	2.254	-2.769	0	-8.165	8.165	0	0
46	3	M10	1	2.254	-2.769	0	-8.165	8.165	0	0
47			2	1.868	-1.772	0	-12.146	12.146	0	0
48			3	1.591	-1.303	0	-13.201	13.201	0	0
49			4	1.382	-1.03	0	-13.332	13.332	0	0
50			5	1.219	-.852	0	-13.104	13.104	0	0
51	3	M11	1	.84	3.577	0	-27.076	28.427	0	0
52			2	.736	2.14	0	-.912	.953	0	0
53			3	.652	1.178	0	10.203	-10.619	0	0
54			4	.582	.487	0	13.553	-14.058	0	0
55			5	.523	-.034	0	12.609	-13.041	0	0
56	3	M12	1	1.682	-2.62	0	0	0	0	0

C22

Company : Robert L. Campbell Structural Engineer, PC
 Designer : KLB
 Job Number : 09123

BET-KO Air

Nov 24, 2009
 2:49 PM
 Checked By: _____

Member Section Stresses (By Combination) (Continued)

LC	Member Label	Sec	Axial[ksi]	y Shear[ksi]	z Shear[ksi]	y top Bendin...	y bot Bendin...	z top Bendin...	z bot Bendin...	
57		2	1.68	-2.62	0	-1.033	1.03	0	0	
58		3	1.678	-2.62	0	-2.066	2.061	0	0	
59		4	1.677	-2.62	0	-3.099	3.091	0	0	
60		5	1.675	-2.62	0	-4.131	4.121	0	0	
61	3	M13	1	1.675	-2.62	0	-4.131	4.121	0	0
62		2	1.498	-1.704	0	-6.339	6.324	0	0	
63		3	1.352	-1.262	0	-7.11	7.095	0	0	
64		4	1.229	-1.002	0	-7.398	7.383	0	0	
65		5	1.125	-0.831	0	-7.474	7.46	0	0	
66	3	M14	1	.84	3.577	0	-27.076	28.427	0	0
67		2	.736	2.14	0	-.912	.953	0	0	
68		3	.652	1.178	0	10.203	-10.619	0	0	
69		4	.582	.487	0	13.553	-14.058	0	0	
70		5	.523	-.034	0	12.609	-13.041	0	0	
71	3	M15	1	.941	0	0	0	0	0	
72		2	.934	0	0	0	0	0	0	
73		3	.927	0	0	0	0	0	0	
74		4	.919	0	0	0	0	0	0	
75		5	.912	0	0	0	0	0	0	
76	3	M16	1	-.232	1.447	0	0	0	0	0
77		2	-.116	.723	0	11.536	-11.536	0	0	
78		3	0	0	0	15.382	-15.382	0	0	
79		4	.116	-.723	0	11.536	-11.536	0	0	
80		5	.232	-1.447	0	0	0	0	0	
81	3	M17	1	2.261	-2.769	0	0	0	0	0
82		2	2.259	-2.769	0	-2.041	2.041	0	0	
83		3	2.257	-2.769	0	-4.083	4.083	0	0	
84		4	2.255	-2.769	0	-6.124	6.124	0	0	
85		5	2.254	-2.769	0	-8.165	8.165	0	0	
86	3	M18	1	2.254	-2.769	0	-8.165	8.165	0	0
87		2	1.868	-1.772	0	-12.146	12.146	0	0	
88		3	1.591	-1.303	0	-13.201	13.201	0	0	
89		4	1.382	-1.03	0	-13.332	13.332	0	0	
90		5	1.219	-.852	0	-13.104	13.104	0	0	
91	3	M19	1	.84	3.577	0	-27.076	28.427	0	0
92		2	.736	2.14	0	-.912	.953	0	0	
93		3	.652	1.178	0	10.203	-10.619	0	0	
94		4	.582	.487	0	13.553	-14.058	0	0	
95		5	.523	-.034	0	12.609	-13.041	0	0	
96	3	M20	1	1.682	-2.62	0	0	0	0	0
97		2	1.68	-2.62	0	-1.033	1.03	0	0	
98		3	1.678	-2.62	0	-2.066	2.061	0	0	
99		4	1.677	-2.62	0	-3.099	3.091	0	0	
100		5	1.675	-2.62	0	-4.131	4.121	0	0	
101	3	M21	1	1.675	-2.62	0	-4.131	4.121	0	0
102		2	1.498	-1.704	0	-6.339	6.324	0	0	
103		3	1.352	-1.262	0	-7.11	7.095	0	0	
104		4	1.229	-1.002	0	-7.398	7.383	0	0	
105		5	1.125	-.831	0	-7.474	7.46	0	0	
106	3	M22	1	.84	3.577	0	-27.076	28.427	0	0
107		2	.736	2.14	0	-.912	.953	0	0	
108		3	.652	1.178	0	10.203	-10.619	0	0	
109		4	.582	.487	0	13.553	-14.058	0	0	
110		5	.523	-.034	0	12.609	-13.041	0	0	
111	3	M23	1	.941	0	0	0	0	0	
112		2	.934	0	0	0	0	0	0	
113		3	.927	0	0	0	0	0	0	

Member Section Stresses (By Combination) (Continued)

LC	Member Label	Sec	Axial[ksi]	y Shear[ksi]	z Shear[ksi]	y top Bendin...	y bot Bendin...	z top Bendin...	z bot Bendin...	
114		4	.919	0	0	0	0	0	0	
115		5	.912	0	0	0	0	0	0	
116	3	M24	1	-.232	1.447	0	0	0	0	
117		2	-.116	.723	0	11.536	-11.536	0	0	
118		3	0	0	0	15.382	-15.382	0	0	
119		4	.116	-.723	0	11.536	-11.536	0	0	
120		5	.232	-1.447	0	0	0	0	0	
121	3	M25	1	1.604	-2.6	0	0	0	0	
122		2	1.602	-2.6	0	-1.802	1.064	0	0	
123		3	1.6	-2.6	0	-3.605	2.128	0	0	
124		4	1.598	-2.6	0	-5.407	3.192	0	0	
125		5	1.597	-2.6	0	-7.21	4.256	0	0	
126	3	M26	1	1.597	-2.6	0	-7.21	4.256	0	0
127		2	1.393	-1.704	0	-10.779	6.679	0	0	
128		3	1.233	-1.267	0	-11.711	7.596	0	0	
129		4	1.102	-1.008	0	-11.822	7.975	0	0	
130		5	.994	-.837	0	-11.623	8.106	0	0	
131	3	M27	1	.827	3.578	0	-26.611	27.939	0	0
132		2	.724	2.141	0	-.554	.578	0	0	
133		3	.641	1.179	0	10.491	-10.919	0	0	
134		4	.572	.488	0	13.792	-14.306	0	0	
135		5	.514	-.034	0	12.812	-13.252	0	0	
136	3	M28	1	3.05	-2.765	0	0	0	0	
137		2	3.052	-2.773	0	-2.052	2.052	0	0	
138		3	3.053	-2.781	0	-4.119	4.119	0	0	
139		4	3.054	-2.789	0	-6.2	6.2	0	0	
140		5	3.056	-2.797	0	-8.295	8.295	0	0	
141	3	M29	1	3.043	-2.765	0	-8.18	8.18	0	0
142		2	2.521	-1.755	0	-12.051	12.051	0	0	
143		3	2.148	-1.286	0	-13.037	13.037	0	0	
144		4	1.867	-1.014	0	-13.129	13.129	0	0	
145		5	1.648	-.837	0	-12.878	12.878	0	0	
146	3	M30	1	.827	3.578	0	-26.611	27.939	0	0
147		2	.724	2.141	0	-.554	.578	0	0	
148		3	.641	1.179	0	10.491	-10.919	0	0	
149		4	.572	.488	0	13.792	-14.306	0	0	
150		5	.514	-.034	0	12.812	-13.252	0	0	
151	3	M31	1	.941	0	0	0	0	0	
152		2	.934	0	0	0	0	0	0	
153		3	.927	0	0	0	0	0	0	
154		4	.919	0	0	0	0	0	0	
155		5	.912	0	0	0	0	0	0	
156	3	M32	1	-.232	1.447	0	0	0	0	0
157		2	-.116	.723	0	11.536	-11.536	0	0	
158		3	0	0	0	15.382	-15.382	0	0	
159		4	.116	-.723	0	11.536	-11.536	0	0	
160		5	.232	-1.447	0	0	0	0	0	
161	3	M33	1	1.222	-1.438	0	0	0	0	0
162		2	1.22	-1.438	0	-1.075	1.052	0	0	
163		3	1.218	-1.438	0	-2.15	2.104	0	0	
164		4	1.217	-1.438	0	-3.225	3.156	0	0	
165		5	1.215	-1.438	0	-4.299	4.209	0	0	
166	3	M34	1	1.215	-1.438	0	-4.299	4.209	0	0
167		2	1.002	-.92	0	-6.381	6.266	0	0	
168		3	.849	-.677	0	-6.925	6.817	0	0	
169		4	.733	-.535	0	-6.986	6.889	0	0	
170		5	.641	-.442	0	-6.859	6.775	0	0	

C24

Company : Robert L. Campbell Structural Engineer, PC
 Designer : KLB
 Job Number : 09123

BET-KO Air

Nov 24, 2009
 2:49 PM
 Checked By: _____

Member Section Stresses (By Combination) (Continued)

	LC	Member Label	Sec	Axial[ksi]	y Shear[ksi]	z Shear[ksi]	y top Bendin...	y bot Bendin...	z top Bendin...	z bot Bendin...
171	3	M35	1	.445	1.918	0	-14.34	15.056	0	0
172			2	.39	1.151	0	-.341	.356	0	0
173			3	.345	.635	0	5.613	-5.842	0	0
174			4	.308	.264	0	7.405	-7.681	0	0
175			5	.277	-.018	0	6.885	-7.121	0	0
176	3	M36	1	.445	1.918	0	-14.34	15.056	0	0
177			2	.39	1.151	0	-.341	.356	0	0
178			3	.345	.635	0	5.613	-5.842	0	0
179			4	.308	.264	0	7.405	-7.681	0	0
180			5	.277	-.018	0	6.885	-7.121	0	0
181	3	M37	1	.506	0	0	0	0	0	0
182			2	.499	0	0	0	0	0	0
183			3	.491	0	0	0	0	0	0
184			4	.484	0	0	0	0	0	0
185			5	.477	0	0	0	0	0	0
186	3	M38	1	-.121	.757	0	0	0	0	0
187			2	-.061	.378	0	6.033	-6.033	0	0
188			3	0	0	0	8.044	-8.044	0	0
189			4	.061	-.378	0	6.033	-6.033	0	0
190			5	.121	-.757	0	0	0	0	0
191	3	M39	1	1.156	-1.355	0	0	0	0	0
192			2	1.155	-1.355	0	-.981	.577	0	0
193			3	1.153	-1.355	0	-1.962	1.155	0	0
194			4	1.151	-1.355	0	-2.943	1.732	0	0
195			5	1.15	-1.355	0	-3.924	2.309	0	0
196	3	M40	1	1.15	-1.355	0	-3.924	2.309	0	0
197			2	.995	-.881	0	-5.789	3.583	0	0
198			3	.874	-.653	0	-6.242	4.05	0	0
199			4	.776	-.518	0	-6.268	4.235	0	0
200			5	.695	-.43	0	-6.138	4.291	0	0

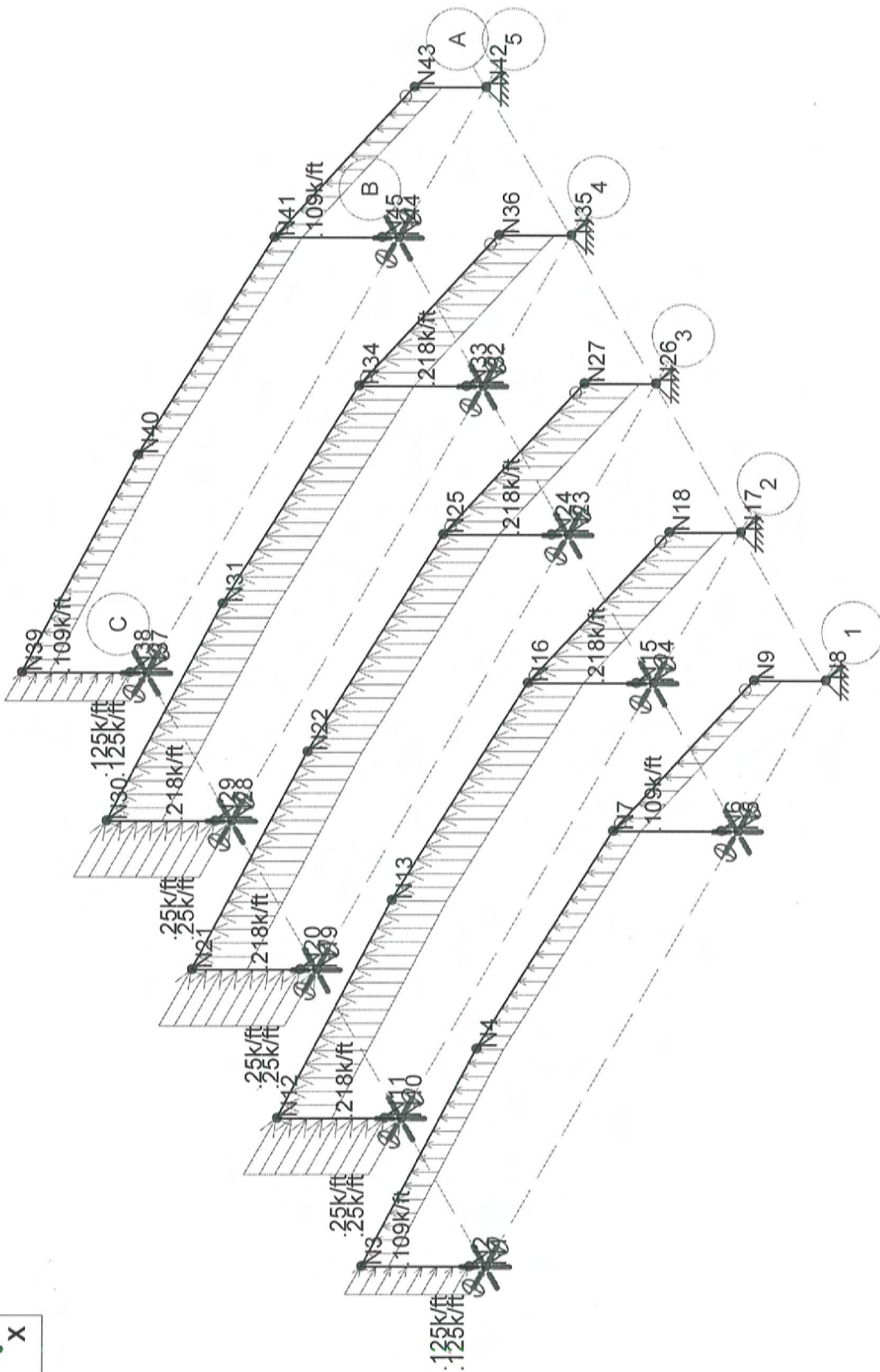
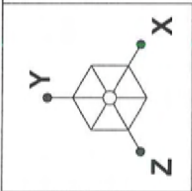

Loads: BLC 4, Wind Load

Robert L. Campbell Structural Engin...

KLB

09123

BET-KO Air

Nov 24, 2009 at 3:02 PM

Grid1-50ksi.r3d

Load Combinations

	Description	Solve	PDelta	SRSS	BLC Factor	BLC Factor	BLC Factor	BLC Factor	BLC Factor	BLC Factor	BLC Factor	BLC Factor	BLC Factor	BLC Factor	BLC Factor	BLC Factor
1	DL	Yes			DL	1										
2	DL+LLr (Existing)				DL	1	RLL	1								
3	DL+CL+LLr (Pr...	Yes			DL	1	OL1	1	RLL	1						
4		Yes														
5	DL+WL	Yes			DL	1	WL	1								

→ This analysis includes 1.33 stress increase

c27

Company : Robert L. Campbell Structural Engineer, PC
 Designer : KLB
 Job Number : 09123

BET-KO Air

Nov 24, 2009
 3:08 PM
 Checked By: _____

Member AISC ASD Steel Code Checks (By Combination)

L	Member	Shape	UC Max	Loc.	Shea.	Loc.	Fa[ksi]	Ft[ksi]	Fby[ksi]	Fbz[ksi]	Cb	Cmy	Cmz	Eqn		
1	5	M1	Col_C1..	.101	2	.051	0	y	36.506	39.9	43.274	41.25	1.75	.6	.85	H2-1
2	5	M2	Col_C1..	.144	4.618	.045	0	y	31.895	39.9	39.9	37.765	1....	1	1	H2-1
3	5	M3	Frame_...	- Taper Comp. flange < Tension flange, per A...												
4	5	M4	Col_B1..	.019	2	.007	0	y	26.508	39.9	43.274	28.681	1.75	.6	.6	H1-3
5	5	M5	Col_B1..	- Taper Comp. flange < Tension flange, per A...												
6	5	M6	Frame_...	- Taper Comp. flange < Tension flange, per A...												
7	5	M7	Col_Gri..	.007	8.417	.000	0	z	20.593	28.728	35.91	28.728	1.75	.6	.6	H2-1
8	5	M8	W10X15	.508	10....	.017	21....	y	21.276	28.728	35.91	6.759	1	.6	1	H1-1
9	5	M9	Col_C1..	.223	2	.110	0	y	36.506	39.9	43.274	41.25	1.75	.6	.85	H2-1
10	5	M10	Col_C1..	.319	4.75	.098	0	y	31.863	39.9	39.9	37.723	1.54	1	1	H2-1
11	5	M11	Frame_...	- Taper Comp. flange < Tension flange, per A...												
12	5	M12	Col_B2..	.037	2	.022	0	y	38.918	39.9	49.875	43.89	1.75	.6	.6	H2-1
13	5	M13	Col_B2..	- Taper Comp. flange < Tension flange, per A...												
14	5	M14	Frame_...	- Taper Comp. flange < Tension flange, per A...												
15	5	M15	Col_Gri..	.016	8.417	.000	0	z	20.593	28.728	35.91	28.728	1.75	.6	.6	H2-1
16	5	M16	W10X15	1.120	10....	.037	21....	y	21.276	28.728	35.91	6.759	1	.6	1	H1-1
17	5	M17	Col_C1..	.223	2	.110	0	y	36.506	39.9	43.274	41.25	1.75	.6	.85	H2-1
18	5	M18	Col_C1..	.319	4.75	.098	0	y	31.863	39.9	39.9	37.723	1.54	1	1	H2-1
19	5	M19	Frame_...	- Taper Comp. flange < Tension flange, per A...												
20	5	M20	Col_B2..	.039	2	.022	0	y	27.142	39.9	49.875	39.9	1.75	.6	.6	H2-1
21	5	M21	Col_B2..	- Taper Comp. flange < Tension flange, per A...												
22	5	M22	Frame_...	- Taper Comp. flange < Tension flange, per A...												
23	5	M23	Col_Gri..	.016	8.417	.000	0	z	20.593	28.728	35.91	28.728	1.75	.6	.6	H2-1
24	5	M24	W10X15	1.120	10....	.037	21....	y	21.276	28.728	35.91	6.759	1	.6	1	H1-1
25	5	M25	Col_C4..	.179	2	.105	0	y	38.875	39.9	43.274	41.25	1.75	.6	.85	H1-3
26	5	M26	Col_C4..	- Taper Comp. flange < Tension flange, per A...												
27	5	M27	Frame_...	- Taper Comp. flange < Tension flange, per A...												
28	5	M28	Col_B4..	.109	2	.025	2	y	25.153	39.9	43.274	25.129	1.75	1	1	H2-1
29	5	M29	Col_B4..	.213	8.445	.029	12....	y	23.894	39.9	39.9	17.085	1....	1	1	H2-1
30	5	M30	Frame_...	- Taper Comp. flange < Tension flange, per A...												
31	5	M31	Col_Gri..	.016	8.417	.000	0	z	20.593	28.728	35.91	28.728	1.75	.6	.6	H2-1
32	5	M32	W10X15	1.120	10....	.037	0	y	21.276	28.728	35.91	6.759	1	.6	1	H1-1
33	5	M33	Col_C5..	.099	2	.050	0	y	36.505	39.9	43.274	41.25	1.75	.6	.85	H2-1
34	5	M34	Col_C5..	- Taper Comp. flange < Tension flange, per A...												
35	5	M35	Frame_...	- Taper Comp. flange < Tension flange, per A...												
36	5	M36	Frame_...	- Taper Comp. flange < Tension flange, per A...												
37	5	M37	Col_Gri..	.007	8.417	.000	0	z	20.593	28.728	35.91	28.728	1.75	.6	.6	H2-1
38	5	M38	W10X15	.508	10....	.017	21....	y	21.276	28.728	35.91	6.759	1	.6	1	H1-1
39	5	M39	Col_B5..	.019	2	.007	0	y	26.394	39.9	43.274	28.55	1.75	.6	.6	H1-3
40	5	M40	Col_B5..	- Taper Comp. flange < Tension flange, per A...												

C28

Company : Robert L. Campbell Structural Engineer, PC
 Designer : KLB
 Job Number : 09123

BET-KO Air

Nov 24, 2009
 3:08 PM
 Checked By: _____

Joint Reactions (By Combination)

	LC	Joint Label	X [k]	Y [k]	Z [k]	MX [k-ft]	MY [k-ft]	MZ [k-ft]
1	5	N1	-2.16	-1.8	0	0	0	0
2	5	N5	.327	-2.023	0	0	0	0
3	5	N8	0	-.667	0	0	0	0
4	5	N10	-4.662	-4.613	0	0	0	0
5	5	N14	.995	-5.222	0	0	0	0
6	5	N17	0	-1.603	0	0	0	0
7	5	N19	-4.662	-4.613	0	0	0	0
8	5	N23	.995	-5.222	0	0	0	0
9	5	N26	0	-1.603	0	0	0	0
10	5	N28	-4.7	-4.52	0	0	0	0
11	5	N32	1.034	-5.409	0	0	0	0
12	5	N35	0	-1.603	0	0	0	0
13	5	N37	-2.162	-1.794	0	0	0	0
14	5	N42	0	-.667	0	0	0	0
15	5	N44	.329	-2.016	0	0	0	0
16	5	Totals:	-14.667	-43.375	0			
17	5	COG (ft):	X: 40.573	Y: 14.89	Z: 39.968			

C29

Company : Robert L. Campbell Structural Engineer, PC
 Designer : KLB
 Job Number : 09123

BET-KO Air

Nov 24, 2009
 3:09 PM
 Checked By: _____

Member Section Forces (By Combination)

	LC	Member Label	Sec	Axial[k]	y Shear[k]	z Shear[k]	Torque[k-ft]	y-y Moment[...]	z-z Moment[...]
1	5	M1	1	-1.8	2.16	0	0	0	0
2			2	-1.808	2.097	0	0	0	-1.064
3			3	-1.815	2.035	0	0	0	-2.097
4			4	-1.823	1.972	0	0	0	-3.099
5			5	-1.831	1.91	0	0	0	-4.07
6	5	M2	1	-1.831	1.91	0	0	0	-4.07
7			2	-1.884	1.514	0	0	0	-9.491
8			3	-1.947	1.118	0	0	0	-13.659
9			4	-2.02	.722	0	0	0	-16.573
10			5	-2.102	.327	0	0	0	-18.234
11	5	M3	1	-.414	-2.087	0	0	0	-18.234
12			2	-.393	-1.594	0	0	0	-4.738
13			3	-.373	-1.117	0	0	0	5.201
14			4	-.354	-.658	0	0	0	11.706
15			5	-.336	-.215	0	0	0	14.901
16	5	M4	1	-2.023	.327	0	0	0	0
17			2	-2.034	.327	0	0	0	-.163
18			3	-2.045	.327	0	0	0	-.327
19			4	-2.056	.327	0	0	0	-.49
20			5	-2.067	.327	0	0	0	-.653
21	5	M5	1	-2.067	.327	0	0	0	-.653
22			2	-2.141	.327	0	0	0	-1.687
23			3	-2.224	.327	0	0	0	-2.721
24			4	-2.318	.327	0	0	0	-3.755
25			5	-2.42	.327	0	0	0	-4.789
26	5	M6	1	-.395	-1.629	0	0	0	-4.789
27			2	-.374	-1.136	0	0	0	5.346
28			3	-.354	-.659	0	0	0	11.924
29			4	-.335	-.2	0	0	0	15.067
30			5	-.317	.243	0	0	0	14.901
31	5	M7	1	-.667	0	0	0	0	0
32			2	-.694	0	0	0	0	0
33			3	-.722	0	0	0	0	0
34			4	-.749	0	0	0	0	0
35			5	-.776	0	0	0	0	0
36	5	M8	1	.228	-.742	0	0	0	0
37			2	.114	-.371	0	0	0	2.96
38			3	0	0	0	0	0	3.947
39			4	-.114	.371	0	0	0	2.96
40			5	-.228	.742	0	0	0	0
41	5	M9	1	-4.613	4.662	0	0	0	0
42			2	-4.621	4.537	0	0	0	-2.3
43			3	-4.628	4.412	0	0	0	-4.537
44			4	-4.636	4.287	0	0	0	-6.712
45			5	-4.643	4.162	0	0	0	-8.824
46	5	M10	1	-4.643	4.162	0	0	0	-8.824
47			2	-4.697	3.37	0	0	0	-20.751
48			3	-4.76	2.579	0	0	0	-30.17
49			4	-4.833	1.787	0	0	0	-37.083
50			5	-4.915	.995	0	0	0	-41.488
51	5	M11	1	-1.199	-4.869	0	0	0	-41.488
52			2	-1.152	-3.731	0	0	0	-9.938
53			3	-1.105	-2.609	0	0	0	13.319
54			4	-1.059	-1.504	0	0	0	28.404
55			5	-1.014	-.417	0	0	0	35.443
56	5	M12	1	-5.222	.995	0	0	0	0

Member Section Forces (By Combination) (Continued)

	LC	Member Label	Sec	Axial[k]	y Shear[k]	z Shear[k]	Torque[k-ft]	y-y Moment[...]	z-z Moment[...]
57			2	-5.236	.995	0	0	0	-.498
58			3	-5.25	.995	0	0	0	-.995
59			4	-5.264	.995	0	0	0	-1.493
60			5	-5.278	.995	0	0	0	-1.991
61	5	M13	1	-5.278	.995	0	0	0	-1.991
62			2	-5.371	.995	0	0	0	-5.142
63			3	-5.475	.995	0	0	0	-8.294
64			4	-5.588	.995	0	0	0	-11.446
65			5	-5.711	.995	0	0	0	-14.598
66	5	M14	1	-1.161	-3.953	0	0	0	-14.598
67			2	-1.113	-2.815	0	0	0	10.23
68			3	-1.067	-1.693	0	0	0	26.764
69			4	-1.021	-.588	0	0	0	35.127
70			5	-.975	.499	0	0	0	35.443
71	5	M15	1	-1.603	0	0	0	0	0
72			2	-1.631	0	0	0	0	0
73			3	-1.658	0	0	0	0	0
74			4	-1.685	0	0	0	0	0
75			5	-1.712	0	0	0	0	0
76	5	M16	1	.503	-1.637	0	0	0	0
77			2	.252	-.818	0	0	0	6.529
78			3	0	0	0	0	0	8.705
79			4	-.252	.818	0	0	0	6.529
80			5	-.503	1.637	0	0	0	0
81	5	M17	1	-4.613	4.662	0	0	0	0
82			2	-4.621	4.537	0	0	0	-2.3
83			3	-4.628	4.412	0	0	0	-4.537
84			4	-4.636	4.287	0	0	0	-6.712
85			5	-4.643	4.162	0	0	0	-8.824
86	5	M18	1	-4.643	4.162	0	0	0	-8.824
87			2	-4.697	3.37	0	0	0	-20.751
88			3	-4.76	2.579	0	0	0	-30.17
89			4	-4.833	1.787	0	0	0	-37.083
90			5	-4.915	.995	0	0	0	-41.488
91	5	M19	1	-1.199	-4.869	0	0	0	-41.488
92			2	-1.152	-3.731	0	0	0	-9.938
93			3	-1.105	-2.609	0	0	0	13.319
94			4	-1.059	-1.504	0	0	0	28.404
95			5	-1.014	-.417	0	0	0	35.443
96	5	M20	1	-5.222	.995	0	0	0	0
97			2	-5.236	.995	0	0	0	-.498
98			3	-5.25	.995	0	0	0	-.995
99			4	-5.264	.995	0	0	0	-1.493
100			5	-5.278	.995	0	0	0	-1.991
101	5	M21	1	-5.278	.995	0	0	0	-1.991
102			2	-5.371	.995	0	0	0	-5.142
103			3	-5.475	.995	0	0	0	-8.294
104			4	-5.588	.995	0	0	0	-11.446
105			5	-5.711	.995	0	0	0	-14.598
106	5	M22	1	-1.161	-3.953	0	0	0	-14.598
107			2	-1.113	-2.815	0	0	0	10.23
108			3	-1.067	-1.693	0	0	0	26.764
109			4	-1.021	-.588	0	0	0	35.127
110			5	-.975	.499	0	0	0	35.443
111	5	M23	1	-1.603	0	0	0	0	0
112			2	-1.631	0	0	0	0	0
113			3	-1.658	0	0	0	0	0

Member Section Forces (By Combination) (Continued)

LC	Member Label	Sec	Axial[k]	v Shear[k]	z Shear[k]	Torque[k-ft]	y-v Momentf...	z-z Momentf...
114		4	-1.685	0	0	0	0	0
115		5	-1.712	0	0	0	0	0
116	5	M24	1	.503	-1.637	0	0	0
117		2	.252	-.818	0	0	0	6.529
118		3	0	0	0	0	0	8.705
119		4	-.252	.818	0	0	0	6.529
120		5	-.503	1.637	0	0	0	0
121	5	M25	1	-4.52	4.7	0	0	0
122		2	-4.53	4.575	0	0	0	-2.319
123		3	-4.541	4.45	0	0	0	-4.575
124		4	-4.552	4.325	0	0	0	-6.769
125		5	-4.563	4.2	0	0	0	-8.901
126	5	M26	1	-4.563	4.2	0	0	-8.901
127		2	-4.637	3.409	0	0	0	-20.949
128		3	-4.72	2.617	0	0	0	-30.491
129		4	-4.813	1.825	0	0	0	-37.525
130		5	-4.915	1.034	0	0	0	-42.052
131	5	M27	1	-1.237	-4.868	0	0	-42.052
132		2	-1.19	-3.729	0	0	0	-10.513
133		3	-1.143	-2.608	0	0	0	12.731
134		4	-1.097	-1.503	0	0	0	27.805
135		5	-1.052	-.415	0	0	0	34.833
136	5	M28	1	-5.409	1.034	0	0	0
137		2	-5.417	1.034	0	0	0	-.517
138		3	-5.425	1.034	0	0	0	-1.034
139		4	-5.432	1.034	0	0	0	-1.551
140		5	-5.44	1.034	0	0	0	-2.067
141	5	M29	1	-5.44	1.034	0	0	-2.067
142		2	-5.493	1.034	0	0	0	-5.341
143		3	-5.556	1.034	0	0	0	-8.615
144		4	-5.628	1.034	0	0	0	-11.888
145		5	-5.711	1.034	0	0	0	-15.162
146	5	M30	1	-1.199	-3.952	0	0	-15.162
147		2	-1.152	-2.813	0	0	0	9.654
148		3	-1.105	-1.692	0	0	0	26.176
149		4	-1.059	-.587	0	0	0	34.528
150		5	-1.014	.501	0	0	0	34.833
151	5	M31	1	-1.603	0	0	0	0
152		2	-1.631	0	0	0	0	0
153		3	-1.658	0	0	0	0	0
154		4	-1.685	0	0	0	0	0
155		5	-1.712	0	0	0	0	0
156	5	M32	1	.503	-1.637	0	0	0
157		2	.252	-.818	0	0	0	6.529
158		3	0	0	0	0	0	8.705
159		4	-.252	.818	0	0	0	6.529
160		5	-.503	1.637	0	0	0	0
161	5	M33	1	-1.794	2.162	0	0	0
162		2	-1.802	2.1	0	0	0	-1.066
163		3	-1.81	2.037	0	0	0	-2.1
164		4	-1.818	1.975	0	0	0	-3.103
165		5	-1.826	1.912	0	0	0	-4.075
166	5	M34	1	-1.826	1.912	0	0	-4.075
167		2	-1.88	1.517	0	0	0	-9.505
168		3	-1.944	1.121	0	0	0	-13.681
169		4	-2.018	.725	0	0	0	-16.603
170		5	-2.102	.329	0	0	0	-18.272

Member Section Forces (By Combination) (Continued)

	LC	Member Label	Sec	Axial[k]	y Shear[k]	z Shear[k]	Torque[k-ft]	y-y Moment[...]	z-z Moment[...]
171	5	M35	1	-.416	-2.087	0	0	0	-18.272
172			2	-.396	-1.594	0	0	0	-4.776
173			3	-.376	-1.117	0	0	0	5.162
174			4	-.357	-.658	0	0	0	11.666
175			5	-.338	-.215	0	0	0	14.859
176	5	M36	1	-.397	-1.629	0	0	0	-4.827
177			2	-.377	-1.136	0	0	0	5.307
178			3	-.357	-.659	0	0	0	11.884
179			4	-.338	-.2	0	0	0	15.027
180			5	-.319	.243	0	0	0	14.859
181	5	M37	1	-.667	0	0	0	0	0
182			2	-.694	0	0	0	0	0
183			3	-.722	0	0	0	0	0
184			4	-.749	0	0	0	0	0
185			5	-.776	0	0	0	0	0
186	5	M38	1	.228	-.742	0	0	0	0
187			2	.114	-.371	0	0	0	2.96
188			3	0	0	0	0	0	3.947
189			4	-.114	.371	0	0	0	2.96
190			5	-.228	.742	0	0	0	0
191	5	M39	1	-2.016	.329	0	0	0	0
192			2	-2.027	.329	0	0	0	-.165
193			3	-2.038	.329	0	0	0	-.329
194			4	-2.049	.329	0	0	0	-.494
195			5	-2.06	.329	0	0	0	-.658
196	5	M40	1	-2.06	.329	0	0	0	-.658
197			2	-2.135	.329	0	0	0	-1.7
198			3	-2.22	.329	0	0	0	-2.743
199			4	-2.315	.329	0	0	0	-3.785
200			5	-2.42	.329	0	0	0	-4.827

Member Section Stresses (By Combination)

	LC	Member Label	Sec	Axial[ksi]	y Shear[ksi]	z Shear[ksi]	y top Bendin...	y bot Bendin...	z top Bendin...	z bot Bendin...
1	5	M1	1	-4	1.35	0	0	0	0	0
2			2	-402	1.311	0	.981	-.981	0	0
3			3	-403	1.272	0	1.933	-1.933	0	0
4			4	-405	1.233	0	2.856	-2.856	0	0
5			5	-407	1.194	0	3.75	-3.75	0	0
6	5	M2	1	-407	1.194	0	3.75	-3.75	0	0
7			2	-.349	.606	0	5.036	-5.036	0	0
8			3	-.309	.329	0	4.883	-4.883	0	0
9			4	-.281	.168	0	4.336	-4.336	0	0
10			5	-.26	.063	0	3.677	-3.677	0	0
11	5	M3	1	-.072	-.771	0	7.597	-7.976	0	0
12			2	-.061	-.471	0	1.487	-1.554	0	0
13			3	-.053	-.275	0	-1.288	1.34	0	0
14			4	-.045	-.139	0	-2.36	2.448	0	0
15			5	-.04	-.04	0	-2.504	2.59	0	0
16	5	M4	1	-.315	.198	0	0	0	0	0
17			2	-.316	.198	0	.138	-.08	0	0
18			3	-.318	.198	0	.275	-.161	0	0
19			4	-.32	.198	0	.413	-.241	0	0
20			5	-.321	.198	0	.551	-.321	0	0
21	5	M5	1	-.321	.198	0	.551	-.321	0	0
22			2	-.293	.129	0	.815	-.5	0	0
23			3	-.271	.095	0	.881	-.566	0	0
24			4	-.255	.076	0	.887	-.593	0	0
25			5	-.243	.063	0	.87	-.602	0	0
26	5	M6	1	-.069	-.602	0	1.995	-2.095	0	0
27			2	-.058	-.336	0	-1.678	1.754	0	0
28			3	-.05	-.162	0	-2.952	3.073	0	0
29			4	-.043	-.042	0	-3.038	3.151	0	0
30			5	-.037	.045	0	-2.504	2.59	0	0
31	5	M7	1	-.175	0	0	0	0	0	0
32			2	-.182	0	0	0	0	0	0
33			3	-.189	0	0	0	0	0	0
34			4	-.196	0	0	0	0	0	0
35			5	-.204	0	0	0	0	0	0
36	5	M8	1	.052	-.323	0	0	0	0	0
37			2	.026	-.161	0	-2.575	2.575	0	0
38			3	0	0	0	-3.434	3.434	0	0
39			4	-.026	.161	0	-2.575	2.575	0	0
40			5	-.052	.323	0	0	0	0	0
41	5	M9	1	-1.025	2.914	0	0	0	0	0
42			2	-1.027	2.836	0	2.119	-2.119	0	0
43			3	-1.028	2.758	0	4.181	-4.181	0	0
44			4	-1.03	2.679	0	6.184	-6.184	0	0
45			5	-1.032	2.601	0	8.131	-8.131	0	0
46	5	M10	1	-1.032	2.601	0	8.131	-8.131	0	0
47			2	-.87	1.348	0	11.009	-11.009	0	0
48			3	-.756	.758	0	10.786	-10.786	0	0
49			4	-.671	.416	0	9.702	-9.702	0	0
50			5	-.607	.191	0	8.366	-8.366	0	0
51	5	M11	1	-.208	-1.8	0	17.286	-18.148	0	0
52			2	-.179	-1.103	0	3.12	-3.26	0	0
53			3	-.155	-.643	0	-3.298	3.432	0	0
54			4	-.136	-.318	0	-5.727	5.94	0	0
55			5	-.12	-.077	0	-5.957	6.161	0	0
56	5	M12	1	-.635	.588	0	0	0	0	0

C34

Company : Robert L. Campbell Structural Engineer, PC
 Designer : KLB
 Job Number : 09123

BET-KO Air

Nov 24, 2009
 3:09 PM
 Checked By: _____

Member Section Stresses (By Combination) (Continued)

LC	Member Label	Sec	Axial[ksi]	y Shear[ksi]	z Shear[ksi]	y top Bendin...	y bot Bendin...	z top Bendin...	z bot Bendin...	
57		2	-.636	.588	0	.232	-.231	0	0	
58		3	-.638	.588	0	.464	-.463	0	0	
59		4	-.64	.588	0	.696	-.694	0	0	
60		5	-.641	.588	0	.928	-.926	0	0	
61	5	M13	1	-.641	.588	0	.928	-.926	0	0
62		2	-.588	.383	0	1.424	-1.421	0	0	
63		3	-.545	.284	0	1.597	-1.594	0	0	
64		4	-.51	.225	0	1.662	-1.658	0	0	
65		5	-.481	.187	0	1.679	-1.676	0	0	
66	5	M14	1	-.202	-1.461	0	6.082	-6.386	0	0
67		2	-.173	-.832	0	-3.212	3.356	0	0	
68		3	-.15	-.417	0	-6.627	6.897	0	0	
69		4	-.131	-.124	0	-7.082	7.346	0	0	
70		5	-.115	.092	0	-5.957	6.161	0	0	
71	5	M15	1	-.421	0	0	0	0	0	
72		2	-.428	0	0	0	0	0	0	
73		3	-.435	0	0	0	0	0	0	
74		4	-.442	0	0	0	0	0	0	
75		5	-.449	0	0	0	0	0	0	
76	5	M16	1	.114	-.712	0	0	0	0	0
77		2	.057	-.356	0	-5.68	5.68	0	0	
78		3	0	0	0	-7.573	7.573	0	0	
79		4	-.057	.356	0	-5.68	5.68	0	0	
80		5	-.114	.712	0	0	0	0	0	
81	5	M17	1	-1.025	2.914	0	0	0	0	0
82		2	-1.027	2.836	0	2.119	-2.119	0	0	
83		3	-1.028	2.758	0	4.181	-4.181	0	0	
84		4	-1.03	2.679	0	6.184	-6.184	0	0	
85		5	-1.032	2.601	0	8.131	-8.131	0	0	
86	5	M18	1	-1.032	2.601	0	8.131	-8.131	0	0
87		2	-.87	1.348	0	11.009	-11.009	0	0	
88		3	-.756	.758	0	10.786	-10.786	0	0	
89		4	-.671	.416	0	9.702	-9.702	0	0	
90		5	-.607	.191	0	8.366	-8.366	0	0	
91	5	M19	1	-.208	-1.8	0	17.286	-18.148	0	0
92		2	-.179	-1.103	0	3.12	-3.26	0	0	
93		3	-.155	-.643	0	-3.298	3.432	0	0	
94		4	-.136	-.318	0	-5.727	5.94	0	0	
95		5	-.12	-.077	0	-5.957	6.161	0	0	
96	5	M20	1	-.635	.588	0	0	0	0	0
97		2	-.636	.588	0	.232	-.231	0	0	
98		3	-.638	.588	0	.464	-.463	0	0	
99		4	-.64	.588	0	.696	-.694	0	0	
100		5	-.641	.588	0	.928	-.926	0	0	
101	5	M21	1	-.641	.588	0	.928	-.926	0	0
102		2	-.588	.383	0	1.424	-1.421	0	0	
103		3	-.545	.284	0	1.597	-1.594	0	0	
104		4	-.51	.225	0	1.662	-1.658	0	0	
105		5	-.481	.187	0	1.679	-1.676	0	0	
106	5	M22	1	-.202	-1.461	0	6.082	-6.386	0	0
107		2	-.173	-.832	0	-3.212	3.356	0	0	
108		3	-.15	-.417	0	-6.627	6.897	0	0	
109		4	-.131	-.124	0	-7.082	7.346	0	0	
110		5	-.115	.092	0	-5.957	6.161	0	0	
111	5	M23	1	-.421	0	0	0	0	0	0
112		2	-.428	0	0	0	0	0	0	0
113		3	-.435	0	0	0	0	0	0	0

Member Section Stresses (By Combination) (Continued)

LC	Member Label	Sec	Axial[ksil]	v Shear[ksil]	z Shear[ksil]	v top Bendin...	v bot Bendin...	z top Bendin...	z bot Bendin...
114		4	-.442	0	0	0	0	0	0
115		5	-.449	0	0	0	0	0	0
116	5	M24	.114	-.712	0	0	0	0	0
117		2	.057	-.356	0	-5.68	5.68	0	0
118		3	0	0	0	-7.573	7.573	0	0
119		4	-.057	.356	0	-5.68	5.68	0	0
120		5	-.114	.712	0	0	0	0	0
121	5	M25	-.706	2.806	0	0	0	0	0
122		2	-.708	2.732	0	1.92	-1.133	0	0
123		3	-.709	2.657	0	3.788	-2.236	0	0
124		4	-.711	2.582	0	5.604	-3.308	0	0
125		5	-.713	2.508	0	7.369	-4.35	0	0
126	5	M26	-.713	2.508	0	7.369	-4.35	0	0
127		2	-.637	1.334	0	10.036	-6.219	0	0
128		3	-.578	.761	0	9.84	-6.382	0	0
129		4	-.532	.423	0	8.858	-5.975	0	0
130		5	-.495	.199	0	7.653	-5.337	0	0
131	5	M27	-.215	-1.799	0	17.521	-18.395	0	0
132		2	-.185	-1.103	0	3.3	-3.449	0	0
133		3	-.161	-.643	0	-3.152	3.281	0	0
134		4	-.141	-.317	0	-5.606	5.815	0	0
135		5	-.124	-.077	0	-5.854	6.055	0	0
136	5	M28	-1.209	.656	0	0	0	0	0
137		2	-1.212	.658	0	.487	-.487	0	0
138		3	-1.215	.66	0	.978	-.978	0	0
139		4	-1.218	.662	0	1.472	-1.472	0	0
140		5	-1.22	.664	0	1.969	-1.969	0	0
141	5	M29	-1.216	.656	0	1.942	-1.942	0	0
142		2	-1.021	.417	0	2.861	-2.861	0	0
143		3	-.884	.305	0	3.095	-3.095	0	0
144		4	-.782	.241	0	3.117	-3.117	0	0
145		5	-.705	.199	0	3.057	-3.057	0	0
146	5	M30	-.208	-1.461	0	6.317	-6.632	0	0
147		2	-.179	-.832	0	-3.031	3.167	0	0
148		3	-.155	-.417	0	-6.481	6.745	0	0
149		4	-.136	-.124	0	-6.961	7.22	0	0
150		5	-.12	.093	0	-5.854	6.055	0	0
151	5	M31	-.421	0	0	0	0	0	0
152		2	-.428	0	0	0	0	0	0
153		3	-.435	0	0	0	0	0	0
154		4	-.442	0	0	0	0	0	0
155		5	-.449	0	0	0	0	0	0
156	5	M32	.114	-.712	0	0	0	0	0
157		2	.057	-.356	0	-5.68	5.68	0	0
158		3	0	0	0	-7.573	7.573	0	0
159		4	-.057	.356	0	-5.68	5.68	0	0
160		5	-.114	.712	0	0	0	0	0
161	5	M33	-.392	1.325	0	0	0	0	0
162		2	-.393	1.287	0	.976	-.956	0	0
163		3	-.395	1.248	0	1.924	-1.883	0	0
164		4	-.397	1.21	0	2.843	-2.783	0	0
165		5	-.398	1.172	0	3.733	-3.654	0	0
166	5	M34	-.398	1.172	0	3.733	-3.654	0	0
167		2	-.342	.595	0	5.002	-4.912	0	0
168		3	-.303	.323	0	4.844	-4.769	0	0
169		4	-.275	.165	0	4.298	-4.238	0	0
170		5	-.255	.062	0	3.642	-3.597	0	0

C36

Company : Robert L. Campbell Structural Engineer, PC
 Designer : KLB
 Job Number : 09123

BET-KO Air

Nov 24, 2009
 3:09 PM
 Checked By: _____

Member Section Stresses (By Combination) (Continued)

	LC	Member Label	Sec	Axial[ksi]	y Shear[ksi]	z Shear[ksi]	y top Bendin...	y bot Bendin...	z top Bendin...	z bot Bendin...
171	5	M35	1	-.072	-.771	0	7.613	-7.993	0	0
172			2	-.062	-.471	0	1.499	-1.567	0	0
173			3	-.053	-.275	0	-1.278	1.33	0	0
174			4	-.046	-.139	0	-2.352	2.439	0	0
175			5	-.04	-.04	0	-2.497	2.583	0	0
176	5	M36	1	-.069	-.602	0	2.011	-2.112	0	0
177			2	-.059	-.336	0	-1.666	1.741	0	0
178			3	-.05	-.162	0	-2.943	3.062	0	0
179			4	-.043	-.042	0	-3.03	3.142	0	0
180			5	-.038	.045	0	-2.497	2.583	0	0
181	5	M37	1	-.175	0	0	0	0	0	0
182			2	-.182	0	0	0	0	0	0
183			3	-.189	0	0	0	0	0	0
184			4	-.196	0	0	0	0	0	0
185			5	-.204	0	0	0	0	0	0
186	5	M38	1	.052	-.323	0	0	0	0	0
187			2	.026	-.161	0	-2.575	2.575	0	0
188			3	0	0	0	-3.434	3.434	0	0
189			4	-.026	.161	0	-2.575	2.575	0	0
190			5	-.052	.323	0	0	0	0	0
191	5	M39	1	-.31	.19	0	0	0	0	0
192			2	-.312	.19	0	.138	-.081	0	0
193			3	-.314	.19	0	.275	-.162	0	0
194			4	-.315	.19	0	.413	-.243	0	0
195			5	-.317	.19	0	.55	-.324	0	0
196	5	M40	1	-.317	.19	0	.55	-.324	0	0
197			2	-.287	.124	0	.812	-.502	0	0
198			3	-.266	.092	0	.875	-.568	0	0
199			4	-.249	.073	0	.879	-.594	0	0
200			5	-.237	.06	0	.861	-.602	0	0